On Friday, September 1, 2023, at or before 4:59 p.m., agenda was posted at the front doors of City Hall, on the bulletin board in the lobby of City Hall, and on the City of Bethany website: cityofbethany.org. The City of Bethany encourages participation from all its citizens. If participation at any public meeting is not possible due to a disability, notification to the City Clerk at least 48 hours prior to the scheduled meeting is encouraged to make the necessary accommodations. The City may waive the 48-hour rule if signing is not the necessary accommodation.

AGENDA

BETHANY CITY COUNCIL

TUESDAY, SEPTEMBER 5, 2023
6:30 P.M.

BETHANY CITY HALL
6714 NW 36TH ST
BETHANY, OKLAHOMA



With the exception of new business, official action can only occur on items which appear on the agenda. The Council may adopt, approve, ratify, deny, defer, recommend, amend, strike, or continue any agenda item. When more information is needed to act on an item, Council may refer the matter to the City Manager or the Municipal Counselor. The Council may also refer items to standing committees of the Council or to a board or commission for additional study. Under certain circumstances, items may be deferred to a specific later date or stricken from the agenda entirely.

1. Call to Order
2. Invocation and Flag Salute
3. Consent Docket:
 - A. Approval of Minutes from the August 15, 2023, Regular Meeting.
 - B. Approval of Claims: These claims have been found to be in order by staff and proper as to form and procedure and are recommended for payment. A copy of the Claims List is included in the agenda packet.
 - C. Approval of Budget Amendment No. 24-2.
 - D. Approval of Budget Amendment No. 24-3
 - E. Approval of Budget Amendment No. 24-4.
 - F. Approval of Budget Amendment No. 24-5.
4. Public Comment - Any person wishing to address the Council during Public Comment shall give their name, address, and city of residence to the City Clerk for the records PRIOR to the start of the meeting. *(Per Chapter 30 of the Bethany Code of Ordinances, there is a five-minute limit, and no action or discussion shall take place. All remarks shall be addressed to the Council as a body, and not to any member thereof.)*

5. Consideration and possible approval to appoint Marilyn Wetmore to the Metropolitan Library Commission of Oklahoma County to serve a three-year term ending on July 31, 2026. *(Nikki Lloyd, Mayor)*
6. Consideration and possible approval to acknowledge Oklahoma Water Resources Board (OWRB) grant award and open a bank account to receive the OWRB grant in the amount of \$100,000 to pay for a portion of the NW 23rd Street and Council Road emergency. *(Elizabeth Gray, City Manager)*
7. Consideration and possible approval of Interlocal Agreement with Bethany Public Schools to clean and paint the water tower located near NW 50th Street and McMillan Avenue and authorize the mayor to sign the document on behalf of the City of Bethany. *(Elizabeth Gray, City Manager)*
8. Water report by city engineers from TEIM Design with possible discussion. *(Elizabeth Gray, City Manager)*
9. Consideration and possible approval to give TEIM Design permission to advertise for bids for the Cecil Mendenall Park Restroom (G.O. Bond Proposition 2-F). *(Elizabeth Gray, City Manager)*
10. Consideration and possible approval to repeal the motion approved on June 1, 2021, regarding July 4th activities and to support city staff with the ability to provide for an annual parade and fireworks to celebrate Independence Day. *(Jeff Knapp, Vice-Mayor)*
11. Consideration and possible action to approve or reject the Charter Review Committee proposals submitted to the Council for review, in part or in whole, and possible action to reconvene the Charter Review Committee to review and make suggested changes to certain proposals. *(Ray Jones, City Attorney & Chris Powell, Council Member)*
12. Consideration and possible action to schedule a public workshop in September to discuss utility rate adjustments. *(Ray Jones, City Attorney)*
13. EXECUTIVE SESSION: Confidential communications between City Council and City Attorney pursuant to 25 O.S. § 307 (B) (4) concerning Oklahoma County Cases CJ-2023-2817 and CJ-2023-2816 under advice of City Attorney that disclosure will seriously impair the ability of the City Council to conduct litigation in the public interest.
 - A. Enter into Executive Session.
 - B. Exit Executive Session.
14. EXECUTIVE SESSION: Confidential communications between City Council, City Attorney and Tony Puckett, attorney with McAfee and Taft, and co-counsel Matt Sill, pursuant to 25 O.S. § 307 (B) (4) concerning the matter pending in the United States District Court of South Carolina, Case MDL NO. 2873, for discussion of litigation on behalf of the City of Bethany against manufacturers of Aqueous Film-Foaming Foam and other “forever” chemicals for contamination of water under advice of City

Attorney that disclosure will seriously impair the ability of the City Council to conduct litigation in the public interest.

- A. Enter into Executive Session.
- B. Exit Executive Session.

15. Consideration and possible action to retain Tony Puckett, attorney with McAfee and Taft, and co-counsel Matt Sill to represent the City of Bethany in United States District Court of South Carolina, Case MDL NO. 2873, and other potential litigation against manufacturers of Aqueous Film Foaming Foam.
16. New Business *(As defined by the Oklahoma Open Meeting Act § 311 (A) (9) as “matters not known about or which could not have reasonably been foreseen prior to the time of posting the agenda”).*
17. City Attorney’s Report.
18. City Manager’s Report.
19. Mayor and Council Members Comments and Suggestions.
20. Adjourn until September 19, 2023.

BETHANY PUBLIC WORKS AUTHORITY

With the exception of new business, official action can only occur on items which appear on the agenda. The Council may adopt, approve, ratify, deny, defer, recommend, amend, strike, or continue any agenda item. When more information is needed to act on an item, Council may refer the matter to the City Manager or the Municipal Counselor. The Council may also refer items to standing committees of the Council or to a board or commission for additional study. Under certain circumstances, items may be deferred to a specific later date or stricken from the agenda entirely.

1. Consent Docket:
 - A. Approval of Minutes from the August 15, 2023, Regular Meeting.
 - B. Approval of Claims: These claims have been found to be in order by staff and proper as to form and procedure and are recommended for payment. A copy of the Claims List is included in the agenda packet.
2. Consideration and possible approval to acknowledge Oklahoma Water Resources Board (OWRB) grant award and open a bank account to receive the OWRB grant in the amount of \$100,000 to pay for a portion of the NW 23rd Street and Council Road emergency. *(Elizabeth Gray, City Manager)*
3. New Business *(As defined by the Oklahoma Open Meeting Act § 311 (A) (9) as “matters not known about or which could not have reasonably been foreseen prior to the time of posting the agenda”).*
4. Adjourn until September 19, 2023.

BETHANY HOSPITAL TRUST

With the exception of new business, official action can only occur on items which appear on the agenda. The Council may adopt, approve, ratify, deny, defer, recommend, amend, strike, or continue any agenda item. When more information is needed to act on an item, Council may refer the matter to the City Manager or the Municipal Counselor. The Council may also refer items to standing committees of the Council or to a board or commission for additional study. Under certain circumstances, items may be deferred to a specific later date or stricken from the agenda entirely.

1. Consent Docket:
 - A. Approval of Minutes from the August 15, 2023, Regular Meeting.
 - B. Approval of Claims: These claims have been found to be in order by staff and proper as to form and procedure and are recommended for payment. A copy of the Claims List is included in the agenda packet.
2. New Business *(As defined by the Oklahoma Open Meeting Act § 311 (A) (9) as “matters not known about or which could not have reasonably been foreseen prior to the time of posting the agenda”).*
3. Adjourn until September 19, 2023.

BETHANY DEVELOPMENT AUTHORITY

With the exception of new business, official action can only occur on items which appear on the agenda. The Council may adopt, approve, ratify, deny, defer, recommend, amend, strike, or continue any agenda item. When more information is needed to act on an item, Council may refer the matter to the City Manager or the Municipal Counselor. The Council may also refer items to standing committees of the Council or to a board or commission for additional study. Under certain circumstances, items may be deferred to a specific later date or stricken from the agenda entirely.

1. Consent Docket:
 - A. Approval of Minutes from the August 15, 2023, Regular Meeting.
 - B. Approval of Claims: These claims have been found to be in order by staff and proper as to form and procedure and are recommended for payment. A copy of the Claims List is included in the agenda packet.
2. New Business *(As defined by the Oklahoma Open Meeting Act § 311 (A) (9) as “matters not known about or which could not have reasonably been foreseen prior to the time of posting the agenda”).*
3. Adjourn until September 19, 2023.

Public Participation Note: The City Council and Staff of the City of Bethany strongly encourages the input and involvement of the citizens to help ensure that the city government provides the highest level of services to meet the public needs and desires. If you have any concerns or comments about an agenda item, or any other issue, please contact the Mayor, your Ward Council Members or City Hall Staff. You may also contact the City Manager's office if you would like to have an item placed on a future agenda to address the Council as a whole. (Guidelines are available in the Council Chambers and in City Hall Lobby.)

NOTICE: On Monday, August 14, 2023, at or before 4:59 p.m., agenda was posted at the front doors of City Hall, on the bulletin board in the lobby of City Hall, and on the City of Bethany website: cityofbethany.org. The City of Bethany encourages participation from all its citizens. If participation at any public meeting is not possible due to a disability, notification to the City Clerk at least 48 hours prior to the scheduled meeting is encouraged to make the necessary accommodations. The City may waive the 48-hour rule if signing is not the necessary accommodation.

BETHANY CITY COUNCIL MEETING

BETHANY CITY HALL

TUESDAY, AUGUST 15, 2023

6:30 P.M.

MEMBERS PRESENT:	Nikki Lloyd	Mayor
	Jeff Knapp	Vice- Mayor
	Brian Magirowsky	Council Member
	Chris Powell	Council Member
	Jeff Knapp	Council Member
	Marilyn McPhail	Council Member
	Kathy Larsen	Council Member
	Ken Smart	Council Member
	Peter Plank	Council Member
	Steve Palmer	Council Member

MEMBERS ABSENT: None

OTHERS PRESENT:	Elizabeth Gray	City Manager
	Ray Jones	City Attorney
	Michael Vaughn	City Clerk/Treasurer
	Lesa LaMar	Deputy City Clerk
	Troy Rhodes	Architect
	(See Roster)	

ITEM NO. 1 on the agenda Mayor **CALL TO ORDER.**

Mayor Lloyd called the Bethany City Council meeting to order at 6:30 P.M.

ITEM NO. 2 on the agenda was **INVOCATION AND FLAG SALUTE.**

The Invocation was given by Council Member Larsen.

The Flag Salute was conducted by Mayor Lloyd.

ITEM NO. 3 on the agenda was **CONSENT DOCKET:**

- A. APPROVAL OF MINUTES FROM AUGUST 1, 2023, REGULAR MEETING.**
- B. APPROVAL OF CLAIMS: THESE CLAIMS HAVE BEEN FOUND TO BE IN ORDER BY STAFF AND PROPER AS TO FORM AND PROCEDURE AND ARE RECOMMENDED FOR PAYMENT. A COPY OF THE CLAIMS.**
- C. APPROVAL OF BUDGET AMENDMENT 24-1.**

Motion was made by Council Member Magirowsky, seconded by Council Member Larsen to approve the consent docket. Yes votes: Palmer, Plank, Larsen, McPhail, Magirowsky, Smart, Powell, Knapp, Lloyd. No votes: None. Motion approved.

ITEM NO. 4 on the agenda was **EXECUTIVE SESSION: CONSIDERATION AND POSSIBLE ACTION TO ENTER INTO EXECUTIVE SESSION TO DISCUSS THE STATUS OF NEGOTIATIONS BETWEEN THE CITY OF BETHANY AND FOP LODGE NO. 161 AS AUTHORIZED BY 25 O.S. SECTION 307 (B) (2). (TABLED FROM 08/01/2023 REGULAR MEETING.) (ELIZABETH GRAY, CITY MANAGER)**

- A. ENTER EXECUTIVE SESSION.**

Motion was made by Council Member Magirowsky, seconded by Council Member McPhail to enter executive session at 6:32 p.m. Yes votes: Plank, Lloyd, Powell, McPhail, Magirowsky, Palmer, Smart, Knapp, Larsen. No votes: None. Motion approved.

- B. EXIT EXECUTIVE SESSION.**

Motion was made by Council Member Magirowsky, seconded by Council Member Larsen to exit executive session at 7:07 p.m. No action was taken. Yes votes: Larsen, Plank, Palmer, McPhail, Lloyd, Magirowsky, Smart, Powell, Knapp. No votes: None. Motion approved.

ITEM NO. 5. on the agenda was **CONSIDERATION AND POSSIBLE ACTION TO APPROVE A NEW COLLECTIVE BARGAINING AGREEMENT FOR FY 2024 AND FY 2025 BETWEEN THE CITY OF BETHANY AND FOP LODGE NO. 161. (ELIZABETH GRAY, CITY MANAGER)**

A motion was made by Council Member Magirowsky, seconded by Council Member Palmer to approve a new Collective Bargaining Agreement for FY 2024 and FY 2025 between the City of Bethany and FOP Lodge No. 161. Yes votes: McPhail, Knapp, Powell, Magirowsky, Smart, Larsen, Plank, Palmer, Lloyd. No votes: None. Motion approved.

ITEM NO. 6 on the agenda was **PUBLIC COMMENT - ANY PERSON WISHING TO ADDRESS THE COUNCIL DURING PUBLIC COMMENT SHALL GIVE THEIR NAME, ADDRESS, AND CITY OF RESIDENCE TO THE CITY CLERK FOR THE RECORDS PRIOR TO THE START OF THE MEETING. (PER CHAPTER 30 OF THE BETHANY CODE OF ORDINANCES, THERE IS A FIVE-MINUTE LIMIT, AND NO ACTION OR DISCUSSION SHALL TAKE PLACE. ALL REMARKS SHALL BE ADDRESSED TO THE COUNCIL AS A BODY, AND NOT TO ANY MEMBER THEREOF.)**

None

ITEM NO. 7 on the agenda was **PUBLIC HEARING ITEM: PRESENTATION, CONSIDERATION, AND POSSIBLE ACTION REGARDING APPROVAL OF A SITE PLAN SUBMITTED BY TROY RHODES, APPLICANT, ON BEHALF OF BETHANY FIRST CHURCH, PROPERTY OWNER, LOCATED AT THE FOLLOWING ADDRESSES: 6910 NW 41ST STREET, 6907 NW 41ST STREET, 6905 NW 41ST STREET, 6903 NW 41ST STREET, 6900 NW 41ST STREET, AND 4201 N WILLOW AVENUE. (ELIZABETH GRAY, CITY MANAGER)**

A. PRESENTATION BY STAFF AND/OR INTERESTED PARTY.

Troy Rhodes represented the Bethany First Church of the Nazarene. See the agenda packet for the presentation that Mr. Rhodes prepared explaining the project.

B. PUBLIC COMMENT.

None.

C. POSSIBLE ACTION.

A motion was made by Council Member Palmer, seconded by Council Member Smart to approve site plan submitted by Troy Rhodes, applicant, on behalf of Bethany First Church, property owner, located at the following addresses: 6910 NW 41st Street, 6907 NW 41st Street, 6905 NW 41st Street, 6903 NW 41st Street, 6900 NW 41st Street, and 4201 N Willow Avenue. Yes votes: Knapp, Powell, Larsen, Plank, McPhail, Smart, Magirowsky, Palmer, Lloyd. No votes: None. Motion approved.

ITEM NO. 8 on the agenda was **CONSIDERATION AND POSSIBLE APPROVAL OF ORDINANCE NO. 2049, AN ORDINANCE ADDING SECTION 50.11 TO THE BETHANY CODE OF ORDINANCES PROVIDING FOR THE PROCEDURES REGARDING TERMINATION OF DELINQUENT UTILITY ACCOUNTS AND PROVIDING FOR PROCEDURES TO TERMINATE DELINQUENT SEWER ACCOUNTS WHERE WATER**

SERVICE IS PROVIDED BY AN ADJACENT MUNICIPALITY. (RAY JONES, CITY ATTORNEY)

A. PRESENTATION BY STAFF AND/OR INTERESTED PARTY.

Attorney Ray Jones informed the council that the City of Bethany does not have an ordinance pursuant to Title 11 Section 22- 112.5. This is a state legislative provision that outlines the procedure for the termination of water services when different public entities that provide public water and waste services are involved. There are at least 3 properties within Bethany that meet these characteristics. This ordinance provides for a hearing process to come before the city council.

B. CONSIDERATION AND POSSIBLE APPROVAL OF ORDINANCE NO. 2049 ON READING BY TITLE ONLY.

A motion was made by Council Member Palmer, seconded by Council Member Larsen to approve B and C of Ordinance No. 2049. Yes votes: Magirowsky, Knapp, Palmer, McPhail, Smart, Larsen, Lloyd, Powell, Plank. No votes: None. Motion approved.

C. CONSIDERATION AND POSSIBLE APPROVAL OF SECTIONS 1-2 OF ORDINANCE NO. 2049.

D. CONSIDERATION AND POSSIBLE APPROVAL OF SECTION 3 OF ORDINANCE NO. 2049, THE EMERGENCY SECTION.

A motion was made by Council Member Palmer, seconded by Council Member Larsen. Yes votes: Magirowsky, Knapp, Larsen, Smart, Plank, McPhail, Powell, Palmer, Lloyd. No votes: None. Motion approved.

ITEM NO. 9 on the agenda was CONSIDERATION AND POSSIBLE APPROVAL OF MAINTENANCE AGREEMENT WITH THE OKLAHOMA DEPARTMENT OF TRANSPORTATION FOR THE UPGRADING OF MULTIPLE TRAFFIC SIGNALS ALONG SH66 FROM ASBURY AVENUE TO PENIEL AVENUE AND AUTHORIZE THE MAYOR TO SIGN THE DOCUMENT ON BEHALF OF THE CITY OF BETHANY. (ELIZABETH GRAY, CITY MANAGER)

City Manager Gray reported that this project will remove on street parking on the North side of SH-66, install sidewalk and ADA compliant ramps and crossings and new decorative pedestrian and traffic signals at the intersections of N. Asbury Avenue, N. College Avenue and N. Peniel Avenue. Approval of this agreement acknowledges that the City is responsible for the maintenance and cost of operation of the new traffic signals.

A motion was made by Council Member Magirowsky, seconded by Council Member Larsen to approve a maintenance agreement with the Oklahoma Department of Transportation for the upgrading of multiple traffic signals along SH66 from Asbury Avenue to Peniel Avenue and authorize the Mayor to sign the document on behalf of the City of Bethany. Yes votes: Magirowsky, Knapp, Larsen, Smart, Plank, McPhail, Powell, Palmer, Lloyd. No votes: None. Motion approved.

ITEM NO. 10 on the agenda was **DISCUSSION AND POSSIBLE ACTION TO APPROVE SOUTHWEST WATER WORKS LLC PAY APPLICATION #1 IN THE AMOUNT OF \$208,311.25 FOR 18607 CDBG 22 WATERLINE REPLACEMENT PROJECT. (ELIZABETH GRAY, CITY MANAGER)**

Motion was made by Council Member Larsen, seconded by Council Member Magirowsky to approve Pay App. #1 to Southwest Water Works LLC in the amount of \$208,311.25 for 18607 CDBG 22 Waterline Replacement Project. Yes votes: Magirowsky, Larsen, McPhail, Lloyd, Palmer, Plank, Smart, Knapp, Powell. No votes: None. Motion approved.

ITEM NO. 11 on the agenda was **CONSIDERATION AND POSSIBLE APPROVAL OF AMENDMENT NO. 1 TO THE CDBG WATERLINE REPLACEMENT PROJECT ON HOLLOWAY AVENUE BETWEEN NW 36TH AND NW 32ND STREETS IN THE AMOUNT OF \$28,115 AND AUTHORIZE THE MAYOR TO SIGN THE DOCUMENT. (ELIZABETH GRAY, CITY MANAGER)**

City Manager Gray informed the council that the scope of Amendment No. 1 is to add a 2-inch waterline, service connections and appurtenances from North Holloway Avenue west approximately 280 feet along the south side of NW 34th Street. The existing 2-inch waterline to connect to is very old and completely incrustated with rust; and requires cleaning for a new connection; and when the pipe is cleaned it makes it thinner and easier to break and creates flat spots and is not circular. New fittings do not attach properly, and leakage would occur, and four residents would be without water. The waterline should be replaced. An additional 6-inch tee, 6-inch gate valve and box, and a plug were added at the southwest corner of NW 34th Street and Holloway Avenue for future waterline extensions. The revised contract amount is now \$283,755.00

Motion was made by Council Member Magirowsky, seconded by Council Member Larsen to approve Amendment #1 to the CDBG Waterline Replacement Project on Holloway Avenue between NW 36th and NW 32nd Streets in the amount of \$28,115 and authorize the Mayor to sign the document. Yes votes: Smart, Larsen, McPhail, Lloyd, Palmer, Plank, Powell, Knapp, Magirowsky. No votes: None. Motion approved.

ITEM NO. 12 on the agenda was **CONSIDERATION AND POSSIBLE APPROVAL TO GIVE TEIM DESIGN PERMISSION TO ADVERTISE THE POLICE HEADQUARTERS**

EXPANSION PROJECT (G.O. BOND PROP 3-B). (ELIZABETH GRAY, CITY MANAGER)

Motion was made by Council Member Larsen, seconded by Council Member Magirowsky to approve giving Teim Design permission to advertise the Police Headquarters Expansion Project. Yes votes: Magirowsky, Larsen, McPhail, Lloyd, Palmer, Plank, Smart, Knapp, Powell. No votes: None. Motion approved.

ITEM NO. 13 on the agenda was CONSIDERATION AND POSSIBLE APPROVAL TO GIVE TEIM DESIGN PERMISSION TO ADVERTISE FOR CONCRETE PAVING, ASPHALT PAVING AND DRAINAGE REPAIRS ON CALL CONTRACT. (ELIZABETH GRAY, CITY MANAGER)

The City Manager explained that this bid is to establish unit prices for work related to concrete paving, asphalt paving and drainage projects. This project is to be used on an as-needed basis for circumstances beyond normal staff operations. Recently there have been instances where repairs from outside contractors were required to address emergency situations for waterlines at 23rd and Council and 58th and Mueller that required pavement and storm sewer removal and replacement. In each instance emergency repairs were required, which meant the cost was not readily identified for the needed work, and at the 23rd and Council location quotes had to be obtained for the permanent repairs. This contract will allow for unit costs to be established, so when an issue arises based on the infrastructure identified as needing repairs, the cost can be determined before the actual repair takes place, eliminating the need for delays or new quotes. There are also time requirements for the contractor to arrive on site and start the repairs.

Motion was made by Council Member Magirowsky, seconded by Council Member Larsen to approve giving Teim Design permission to advertise for concrete paving, asphalt paving and drainage repairs on call contract. Yes votes: Plank, Lloyd, Powell, McPhail, Magirowsky, Palmer, Smart, Knapp, Larsen. No votes: None. Motion approved.

ITEM NO. 14 on the agenda was CONSIDERATION AND POSSIBLE APPROVAL TO GIVE TEIM DESIGN PERMISSION TO ADVERTISE FOR WATER AND SANITARY SEWER REPAIRS ON CALL CONTRACT. (ELIZABETH GRAY, CITY MANAGER)

City Manager Gray stated that this bid is to establish unit prices for work related to water and wastewater projects. This project is to be used on an as-needed basis for circumstances beyond normal staff operations. Recently there have been instances where repairs from outside contractors were required to address emergency situations for waterlines at 23rd and Council and 58th and Mueller, as well as wastewater infrastructure near 55th and Mueller. In each instance emergency repairs were required, which meant the cost was not readily identified for the needed work, and at the 23rd and Council location quotes had to be obtained for the permanent repairs. This contract will allow for unit

costs to be established, so when an issue arises based on the infrastructure identified as needing repairs, the cost can be determined before the actual repair takes place, eliminating the need for delays or new quotes. There are also time requirements for the contractor to arrive on site and start repairs.

Motion was made by Council Member Magirowsky, seconded by Council Member Knapp to approve giving Teim Design permission to advertise for water and sanitary sewer repairs on call contract. Yes votes: Knapp, Palmer, Plank, McPhail, Larsen, Powell, Lloyd, Magirowsky, Smart. No votes: None. Motion approved.

ITEM NO. 15 on the agenda was **NEW BUSINESS (AS DEFINED BY THE OKLAHOMA OPEN MEETING ACT § 311 (A) (9) AS “MATTERS NOT KNOWN ABOUT OR WHICH COULD NOT HAVE REASONABLY BEEN FORESEEN PRIOR TO THE TIME OF POSTING THE AGENDA”)**.

None

ITEM NO. 16 on the agenda was the **CITY ATTORNEY’S REPORT**

Attorney Jones requested that the Charter Review Committee be reappointed to begin review and adjustments of charter amendments that were prepared by the previous committee.

ITEM NO. 17 on the agenda was the **CITY MANAGER’S REPORT.**

City Manager Gray reported the following:

October 2nd is the next Bulk Trash pickup. Pick up will begin on the south side of town.

November 11th is free landfill day from 7:00 a.m. until noon at 7600 SW 15th Street, OKC.

September 4th City offices will be closed. Make up day will be Wednesday, September 6th.

ITEM NO. 18 on the agenda was **COUNCIL MEMBERS’ ANNOUNCEMENTS, COMMENTS, AND PROPOSALS.**

Each Council Member was given the opportunity to comment.

ITEM NO. 19 on the agenda was **ADJOURN UNTIL SEPTEMBER 5, 2023.**

Mayor Lloyd adjourned the Bethany City Council meeting at 7:30 P.M.

Council Member McPhail left the meeting at 7:30 p.m.

MAYOR

CITY CLERK

BETHANY CITY COUNCIL

From: Michael Vaughn, Finance Director
Date: August 30, 2023
Subject: Claims List for the 09/05/2023 City Council Meeting

GENERAL OPERATIONS FUND

FUND	AMOUNT
General Operation Fund	\$1,855.64
General Operation Fund	\$177,414.86
Capital Improvement Projects	\$11,743.69
Federal Grant Fund	\$14,350.00
2022A GO Bond	\$70,854.76
TOTAL	\$276,218.95

ENTERPRISE-WIDE SUMMARY OF ALL CLAIMS:

FUND	AMOUNT
General Operations Fund	\$276,218.95
Bethany Public Works Authority	\$451,606.00
Bethany Hospital Trust	\$0.00
Bethany Development Authority	\$0.00
TOTAL	\$727,824.95

RECOMMENDATION

1. Approve the claims as presented.



FUND: 010- GENERAL FUND

SUMMARY REPORT

P.O.#	VENDOR #	NAME	SUMMARY DESCRIPTION	DATE	INVOICE	AMOUNT	
DEPARTMENT: 05.0		POLICE					
23-47686	10-3415	SPECIAL-OPS UNIFORMS, INC. Sanchez Uniforms		6/2023	342416B	276.00	
23-47687	10-3415	SPECIAL-OPS UNIFORMS, INC. Sanchez Body Armor		6/2023	341835B	981.00	
DEPARTMENT TOTAL:						1,257.00	
DEPARTMENT: 08.5		PUBLIC WORKS - PARKS					
23-47856	10-006099	HAPPY PLAYGROUNDS, LLC	CABLE-ROPE REPLACEMENT	6/2023	2423	508.64	
23-47840	10-0668	HAYES ELECTRIC	DX & POSSIBLE REPAIR PUMP	6/2023	SERVICE CALL90	90.00	
DEPARTMENT TOTAL:						598.64	
FUND TOTAL:						1,855.64	

FUND: 010- GENERAL FUND

SUMMARY REPORT

P.O.#	VENDOR #	NAME	SUMMARY DESCRIPTION	DATE	INVOICE	AMOUNT
DEPARTMENT: 01.0		MANAGEMENT				
24-48170	10-005084	JAN-PRO CLEANING SYSTEMS	CH CLEANING SVC.	8/2023	130948	813.00
24-48470	10-005373	CARD SERVICES/PI	PHONE SCREEN METER READ	8/2023	00588657	18.44
24-48257	10-005519	CRAWFORD & ASSOCIATES, P.C.	AUDIT PREP/FINANCIAL SVC	8/2023	17405	1,762.50
24-48620	10-005539	CENTER FOR ECONOMIC DEVELOPTIF	23RD STREET	8/2023	16036	110.00
24-48587	10-0883	LOCKE SUPPLY CO.	A/C FILTERS	8/2023	50361619-00	224.35
24-48296	10-1068	ONG	MNTHLY SVC	8/2023	20230816	158.57
24-48625	10-1085	OKLAHOMA MUNICIPAL ASSURANCWC	INSURANCE	8/2023	20230829	85.55
24-48584	10-1261	RED ROCK PETRO	5200 UNLEAD&2800 DIESEL	8/2023	1459625	150.94
24-48576	10-1530	THE TRIBUNE	ORDINANCE PUBLICATION	8/2023	20230825	16.85
24-48361	10-2401	HINTON REGRIGERATION CO	DX&POSSIBLYREPAIRHVAC	8/2023	5361	283.75
24-48263	10-3196	IMAGENET CONSULTING, LLC	UPSTAIR/DOWN STAIR COPIER	8/2023	INV655576	240.80
24-48365	10-3196	IMAGENET CONSULTING, LLC	FIRE WALL LICENSE	8/2023	INV650578	553.96
24-48375	10-3331	RUCKER MECHANICAL	CM AIR CONDITIONER	8/2023	92990	325.00
24-48567	10-3331	RUCKER MECHANICAL	UNIT 8 COUNCIL RM AC	8/2023	94087	472.00
24-48589	10-3331	RUCKER MECHANICAL	UNIT #4 A/C CUST SERV	8/2023	94088	990.94
24-48606	10-3331	RUCKER MECHANICAL	UNIT 8 AC	8/2023	94089	1,500.00
DEPARTMENT TOTAL:						7,706.65
DEPARTMENT: 02.0		FINANCE				
24-48625	10-1085	OKLAHOMA MUNICIPAL ASSURANCWC	INSURANCE	8/2023	20230829	85.55
24-48263	10-3196	IMAGENET CONSULTING, LLC	UPSTAIR/DOWN STAIR COPIER	8/2023	INV655576	75.18
24-48365	10-3196	IMAGENET CONSULTING, LLC	FIRE WALL LICENSE	8/2023	INV650578	553.96
DEPARTMENT TOTAL:						714.69
DEPARTMENT: 03.0		COURT				
24-48342	10-006123	CHRISTOPHER T. STEIN	CITY PROSECUTOR FEE	8/2023	230801	1,617.00
24-48296	10-1068	ONG	MNTHLY SVC	8/2023	20230816	49.09
24-48625	10-1085	OKLAHOMA MUNICIPAL ASSURANCWC	INSURANCE	8/2023	20230829	171.09
DEPARTMENT TOTAL:						1,837.18
DEPARTMENT: 04.0		ENGINEERING				
24-48572	10-005900	TEIM DESIGN GROUP, PLLC	CONTRACT ENGINEER SVC	8/2023	12128	27,415.50
DEPARTMENT TOTAL:						27,415.50

FUND: 010- GENERAL FUND

SUMMARY REPORT

P.O.#	VENDOR #	NAME	SUMMARY DESCRIPTION	DATE	INVOICE	AMOUNT
DEPARTMENT: 05.0		POLICE				
24-48219	10-004459	AXON ENTERPRISE, INC.	Taser Instructor School	8/2023	INUS176795	495.00
24-48066	10-004660	MOTHER NATURE'S INC.	Spraying for Bugs Monthly	8/2023	1392740	60.00
24-48596	10-005190	FBI-LEEDA	Command Leadership	8/2023	200088354	795.00
24-48597	10-005190	FBI-LEEDA	Command Leadership	8/2023	200091452	795.00
24-48598	10-005190	FBI-LEEDA	Command Leadership	8/2023	200091391	795.00
24-48461	10-005373	CARD SERVICES/Pl	LEEDA Class for Lt. Plumb	8/2023	200090294	795.00
24-48632	10-005373	CARD SERVICES/Pl	Mounts for Dispatch	8/2023	6445050	79.20
24-48391	10-006120	LEATHER, VINYL AND WOOD SPE	Unit 12-131 Seat	8/2023	17104	600.00
24-48411	10-006120	LEATHER, VINYL AND WOOD SPE	Seat 12-107	8/2023	17108	300.00
24-48562	10-0465	OK DEPT OF PUBLIC SAFETY	OLETS	8/2023	LET-011127	485.00
24-48473	10-0919	MAIL DROP	Mail Case Documents	8/2023	81548	20.45
24-48282	10-1063	OG&E	MNTHLY SVC	8/2023	20230807	23.84
24-48296	10-1068	ONG	MNTHLY SVC	8/2023	20230816	568.96
24-48625	10-1085	OKLAHOMA MUNICIPAL ASSURANC	WC INSURANCE	8/2023	20230829	30,711.64
24-48584	10-1261	RED ROCK PETRO	5200 UNLEAD&2800 DIESEL	8/2023	1459625	8,452.42
24-48543	10-1509	TOM'S SPEEDY LOCK & KEY SER	ACO Keys	8/2023	69557	12.00
24-48410	10-1622	WESTLAKE ACE HARDWARE	Epoxy	8/2023	3503644	7.59
24-48135	10-2442	SUMNERONE, INC.	3 Copier Lease	8/2023	3660161	279.77
24-48137	10-2442	SUMNERONE, INC.	Kyocera Usage	8/2023	3661980	21.55
24-48501	10-3098	TS HEAT AND AIR INC	ANNUAL SERVICE PD	8/2023	21568706	800.00
24-48487	10-3527	GEARWORKS	Durango Decals	8/2023	8856	230.00
24-48068	10-4388	ISG TECHNOLOGY, LLC	Prevntion Security	8/2023	ISG348211	1,204.00
24-48575	10-4388	ISG TECHNOLOGY, LLC	Fortigate Project	8/2023	ISG347755	385.00
DEPARTMENT TOTAL:						47,916.42
DEPARTMENT: 06.0		FIRE				
24-48428	10-005992	AEG PETROLEUM	200 GAL DEF FLUID	8/2023	822823	104.70
24-48282	10-1063	OG&E	MNTHLY SVC	8/2023	20230807	118.52
24-48296	10-1068	ONG	MNTHLY SVC	8/2023	20230816	207.46
24-48625	10-1085	OKLAHOMA MUNICIPAL ASSURANC	WC INSURANCE	8/2023	20230829	22,242.42
24-48584	10-1261	RED ROCK PETRO	5200 UNLEAD&2800 DIESEL	8/2023	1459625	1,473.10
24-48308	10-2305	HIDAILE CO INC	REPAIR SPILL & RISER	8/2023	114120	1,197.95
24-48605	10-2359	TESCORP INC	SCBA COMPRESSOR REPAIRS	8/2023	8558	392.45
24-48365	10-3196	IMAGENET CONSULTING, LLC	FIRE WALL LICENSE	8/2023	INV650578	1,495.68
24-48561	10-3920	OSU OFFICE OF THE BURSAR	INSTRUCTOR UPDATE	8/2023	0089208	100.00
DEPARTMENT TOTAL:						27,332.28

FUND: 010- GENERAL FUND

SUMMARY REPORT

P.O.#	VENDOR #	NAME	SUMMARY DESCRIPTION	DATE	INVOICE	AMOUNT
DEPARTMENT: 07.0		COMMUNITY DEV				
24-48424	10-004417	MCLAIN-CHITWOOD OFFICE	NAME PLATE	8/2023	232596	29.95
24-48482	10-005373	CARD SERVICES/P1	UPDATED CODE BOOKS	8/2023	000069106	1,064.40
24-48507	10-005373	CARD SERVICES/P1	MS4 TRAINING	8/2023	24-48507	375.00
24-48432	10-005689	CHALLENGER LANDSCAPING AND WEED ABATEMENTS		8/2023	8/21/2023	350.00
24-48625	10-1085	OKLAHOMA MUNICIPAL ASSURANCWC INSURANCE		8/2023	20230829	171.09
24-48584	10-1261	RED ROCK PETRO	5200 UNLEAD&2800 DIESEL	8/2023	1459625	754.68
24-48263	10-3196	IMAGENET CONSULTING, LLC	UPSTAIR/DOWN STAIR COPIER	8/2023	INV655576	263.19
24-48365	10-3196	IMAGENET CONSULTING, LLC	FIRE WALL LICENSE	8/2023	INV650578	553.96
24-48617	10-3348	COUNTY CLERK OKLA COUNTY	ABATEMENT	8/2023	24-48617	18.00
24-48618	10-3348	COUNTY CLERK OKLA COUNTY	ABATEMENT	8/2023	24-48618	18.00
24-48619	10-3348	COUNTY CLERK OKLA COUNTY	ABATEMENT	8/2023	24-48619	36.00
24-48481	10-4215	OKLAHOMA CODE ENFORCEMENT	AYEARLY MEMBERSHIP OCEA	8/2023	24-48481	50.00
DEPARTMENT TOTAL:						3,684.27
DEPARTMENT: 08.1		PUBLIC WORKS - ADMIN				
24-48389	10-005373	CARD SERVICES/P1	MONITOR, LAUNDRY SOAP, ZEVO	8/2023	01111436	113.09
24-48580	10-005373	CARD SERVICES/P1	INK, NITRILE GLOVES, GATORAD	8/2023	4427421	40.99
24-48296	10-1068	ONG	MONTHLY SVC	8/2023	20230816	190.60
24-48625	10-1085	OKLAHOMA MUNICIPAL ASSURANCWC INSURANCE		8/2023	20230829	85.55
24-48190	10-2442	SUMNERONE, INC.	MONTHLY COPIER MAINTENANC	8/2023	3667632	41.07
DEPARTMENT TOTAL:						471.30
DEPARTMENT: 08.2		PUBLIC WORKS - STREETS				
24-48225	10-004688	SIGNALTEK, INC.	CHANGE LIGHTS	8/2023	1807B0823	245.50
24-48549	10-004688	SIGNALTEK, INC.	CONFLICT MONITOR	8/2023	1807B0623-	195.00
24-48511	10-004808	ADVANTAGE BATTERY OF OKLAHOSCHOOL ZONE BATTERIES		8/2023	104868	139.98
24-48585	10-004808	ADVANTAGE BATTERY OF OKLAHOSCHOOL ZONE BATTERIES		8/2023	104995	559.92
24-48445	10-005373	CARD SERVICES/P1	SUPPLIES FOR DEPTMENTS	8/2023	5923432	24.06
24-48580	10-005373	CARD SERVICES/P1	INK, NITRILE GLOVES, GATORAD	8/2023	4427421	121.17
24-48428	10-005992	AEG PETROLEUM	200 GAL DEF FLUID	8/2023	822823	104.70
24-48550	10-006081	CH&W COMMERCIAL TIRE, LLC	ALIGNMENT/unit#63bucket	8/2023	3-58714	99.95
24-48327	10-006124	SCHWARZ PAVING CO., INC.	EMERGENCY RKWLL/COUNCIL	8/2023	4890	11,369.76
24-48637	10-0225	GENUINE PARTS	OIL FILTER UNIT #64	8/2023	7092-041303	4.81
24-48395	10-0482	DOLESE BROS. CO.	PALLET OF PORTLAND CEMENT	8/2023	MA23011298	462.28
24-48463	10-0572	REDDY ICE CORP	60 BAGS OF ICE	8/2023	3850645358	37.87
24-48423	10-0694	HASKELL LEMON CONST CO	4 TONS ASPHALT	8/2023	4283	127.20
24-48476	10-0694	HASKELL LEMON CONST CO	6 TONS OF ASPHALT	8/2023	4408	476.00
24-48502	10-0694	HASKELL LEMON CONST CO	4 TONS OF ASPHALT	8/2023	4455	284.80
24-48586	10-0694	HASKELL LEMON CONST CO	5 TONS OF ASPHALT	8/2023	4528	370.40
24-48325	10-0890	LUTHER SIGN CO	2 SIGNS POST	8/2023	13485	88.30
24-48282	10-1063	OG&E	MONTHLY SVC	8/2023	20230807	14,269.33
24-48625	10-1085	OKLAHOMA MUNICIPAL ASSURANCWC INSURANCE		8/2023	20230829	10,094.63
24-48584	10-1261	RED ROCK PETRO	5200 UNLEAD&2800 DIESEL	8/2023	1459625	2,680.59
24-48488	10-1622	WESTLAKE ACE HARDWARE	WIRE CONNECTORS	8/2023	3503659	31.98
24-48419	10-2123	HOME DEPOT CREDIT SVCS	PAINT SUPPLIES	8/2023	009338/1022115	88.47
24-48429	10-2123	HOME DEPOT CREDIT SVCS	SIDED USED FOR PAINTING	8/2023	010616/0022335	38.08

FUND: 010- GENERAL FUND

SUMMARY REPORT

P.O.#	VENDOR #	NAME	SUMMARY DESCRIPTION	DATE	INVOICE	AMOUNT
DEPARTMENT: 08.2 PUBLIC WORKS - STREETS						
24-48450	10-2123	HOME DEPOT CREDIT SVCS	10 BAGS OF CONCRETE	8/2023	014185/6140856	127.06
24-48308	10-2305	HOIDALE CO INC	REPAIR SPILL & RISER	8/2023	114120	1,197.95
24-48142	10-2702	AMERICAN LOGO & SIGNS	31ST TERR & GLADE	8/2023	33145	90.00
24-48258	10-2702	AMERICAN LOGO & SIGNS	SIGNS FOR REPLACEMENT	8/2023	33148	198.00
24-48294	10-2702	AMERICAN LOGO & SIGNS	SIGNS & BRACKETS	8/2023	33149	629.00
DEPARTMENT TOTAL:						44,156.79
DEPARTMENT: 08.4 PUBLIC WORKS - MAINT						
24-48625	10-1085	OKLAHOMA MUNICIPAL ASSURANCWC	INSURANCE	8/2023	20230829	171.10
24-48584	10-1261	RED ROCK PETRO	5200 UNLEAD&2800 DIESEL	8/2023	1459625	528.27
24-48603	10-1622	WESTLAKE ACE HARDWARE	AIR FILTER,PRIMERPVC,SCRE	8/2023	3503676	14.99
24-48563	10-2305	HOIDALE CO INC	SERVICE CALL TEST ERROR	8/2023	1142690	157.25
24-48564	10-3488	CLIFFORD POWER SYSTEMS,	INCDX GENERATOR ISSUES	8/2023	SVC-0151949	169.46
DEPARTMENT TOTAL:						1,041.07
DEPARTMENT: 08.5 PUBLIC WORKS - PARKS						
24-48472	10-004790	HARVEY JANITORIAL SALES	LINERS FOR PARK TRASH CAN	8/2023	211757	341.16
24-48409	10-005005	BRONCO EQUIPMENT RENTAL &	SSTRING LINE FOR WEEDEATER	8/2023	862666-0001	63.99
24-48593	10-005005	BRONCO EQUIPMENT RENTAL &	SPULLEY/BELTFORZTURN	8/2023	863534-0001	95.00
24-48317	10-005350	FORCE PERSONNEL	TEMP HELP FOR PARKS	8/2023	75360	7,540.73
24-48271	10-005373	CARD SERVICES/P1	STORGE CLIPBOARD,WHITEBOA	8/2023	2005005	71.94
24-48425	10-005373	CARD SERVICES/P1	PEDRO D. & MARK LANDERS	8/2023	540301103	56.00
24-48426	10-005373	CARD SERVICES/P1	FLAIL MOWER BLADES	8/2023	189004	552.00
24-48445	10-005373	CARD SERVICES/P1	SUPPLIES FOR DEPTMENTS	8/2023	5923432	24.07
24-48580	10-005373	CARD SERVICES/P1	INK,NITRILEGLOVES,GATORAD	8/2023	4427421	121.17
24-48460	10-005721	ECKROAT SEED CO.	TORDON & ROUND UP	8/2023	107000	220.00
24-48508	10-005943	CENTRAL POWER SYSTEMS AND	SBAR & CHAINS FOR CHAINSAW	8/2023	332964	132.00
24-48428	10-005992	AEG PETROLEUM	200 GAL DEF FLUID	8/2023	822823	13.96
24-48302	10-006099	HAPPY PLAYGROUNDS, LLC	Parts for Hoopla Swing	8/2023	2435	687.18
24-48417	10-0324	CENTRAL POWER EQUIP. INC	WEEDEATER TRIMMER DRUM	8/2023	332407	71.58
24-48463	10-0572	REDDY ICE CORP	60 BAGS OF ICE	8/2023	3850645358	37.88
24-48282	10-1063	OG&E	MNTHLY SVC	8/2023	20230807	230.61
24-48296	10-1068	ONG	MNTHLY SVC	8/2023	20230816	48.18
24-48625	10-1085	OKLAHOMA MUNICIPAL ASSURANCWC	INSURANCE	8/2023	20230829	2,737.53
24-48584	10-1261	RED ROCK PETRO	5200 UNLEAD&2800 DIESEL	8/2023	1459625	1,816.46
24-48479	10-2123	HOME DEPOT CREDIT SVCS	replace kit for sprinkler	8/2023	016559/4014353	18.55
24-48308	10-2305	HOIDALE CO INC	REPAIR SPILL & RISER	8/2023	114120	159.72
24-48321	10-2702	AMERICAN LOGO & SIGNS	2 STREET SIGNS	8/2023	33157	99.00
DEPARTMENT TOTAL:						15,138.71
FUND TOTAL:						177,414.86

FUND: 031- CAPITAL IMPROVE PROJECTS

SUMMARY REPORT

P.O.#	VENDOR #	NAME	SUMMARY DESCRIPTION	DATE	INVOICE	AMOUNT
DEPARTMENT: 40.0		PROJECTS >\$25,000				
24-48503	10-005900	TEIM DESIGN GROUP, PLLC	CRSAA MILL OVERLAY RKWEL	8/2023	12143	9,082.00
24-48566	10-006067	PARKHILL	CDBG GRANT ADMIN	8/2023	01210322.00-4	2,661.69
DEPARTMENT TOTAL:						11,743.69
FUND TOTAL:						11,743.69

P.O.#	VENDOR #	NAME	SUMMARY DESCRIPTION	DATE	INVOICE	AMOUNT
DEPARTMENT: 40.0		Sewer Project				
24-48513	10-005900	TEIM DESIGN GROUP, PLLC	ARPA PENIEL WASTEWATER	8/2023	12145	13,024.50
DEPARTMENT TOTAL:						13,024.50
DEPARTMENT: 42.0		Automated Meter Project				
24-48512	10-005900	TEIM DESIGN GROUP, PLLC	ARPA METER AUTOMATION	8/2023	12146	1,325.50
DEPARTMENT TOTAL:						1,325.50
FUND TOTAL:						14,350.00

P.O.#	VENDOR #	NAME	SUMMARY DESCRIPTION	DATE	INVOICE	AMOUNT
DEPARTMENT: 40.0		Projects				
24-48518	10-005500	TROY D RHODES & COMPANY,	INPROP 3A FIRE STATION RENO	8/2023	03769	23,855.00
24-48573	10-005500	TROY D RHODES & COMPANY,	INFIRE DEPT REIMBURSEABLES	8/2023	03770	212.26
24-48490	10-005900	TEIM DESIGN GROUP, PLLC	PROP 3C ANIMAL WELFARE	8/2023	122141	7,582.00
24-48500	10-005900	TEIM DESIGN GROUP, PLLC	PROP 3B POLICE RENOVATION	8/2023	12142	11,050.50
24-48505	10-005900	TEIM DESIGN GROUP, PLLC	PROP 1 39TH TO 42ND	8/2023	12150	1,339.50
24-48516	10-005900	TEIM DESIGN GROUP, PLLC	PROP 1A&B SIGNALIZATION	8/2023	12144	9,044.25
24-48522	10-005900	TEIM DESIGN GROUP, PLLC	PROP 1F-MUELLER/44 TO 50	8/2023	12148	11,639.00
24-48523	10-005900	TEIM DESIGN GROUP, PLLC	PROP 1G-DIVIS/36 TO 39	8/2023	12147	4,042.25
24-48524	10-005900	TEIM DESIGN GROUP, PLLC	PROP 1E 30/ RKWELL/PENIEL	8/2023	12149	2,090.00
DEPARTMENT TOTAL:						70,854.76
FUND TOTAL:						70,854.76

BETHANY CITY COUNCIL

From: Michael Vaughn, Finance Director
Date: 9/5/2023
Subject: Budget Amendment 24-2

BACKGROUND

In FY 23 the City of Bethany received a matching CDBG grant for a waterline replacement project. This project was budgeted in FY 23, but not completed. There was a remaining balance in that budgeted account of \$293,463. This amount needs to be re-appropriated in FY 24 to pay for the project.

Budget Amendment 24-2 re-appropriates the \$293,463 for the CDBG Waterline Replacement Project in Fiscal year 23-24.

RECOMMENDATION

1. Approve Budget Amendment 24-2(attached).

ADDITIONAL COMMENTS



Approval of and authorization to execute Budget Amendment Number BA# 24-2

BUDGET AMENDMENT FORM



Funds: Capital Improvement Fund
Amendment #: BA #24-2
Fiscal Year: FY2024

<u>Account #</u>	<u>Account Name</u>	<u>Estimated Revenue</u>		<u>Appropriations</u>	
		<u>Increase</u>	<u>Decrease</u>	<u>Increase</u>	<u>Decrease</u>
Capital Improvement Fund					
031-540.0-42014	CDBG Project			293,463	
031-25390	Fund Balance	293,463			
TOTALS		<u>293,463</u>	<u>-</u>	<u>293,463</u>	<u>-</u>

EXPLANATION: 11 OS Section 17-216 B

The Municipal Budget Act adopted by the City Council allows the City to amend the budget at any time during the year for necessary expenditures incurred that exceed the original budget or when changing circumstances warrant the action.

Budget Amendment 24-2 Carries over funds budgeted in the prior year but unspent and appropriates those funds for the completion of the CDBG Project.

Date & Signature of Mayor: _____ x _____ Date

Date & Signature of City Manager: _____ x _____ Date

Date Approved by City Council: September 5th, 2023 _____

Capital Improvement Fund

Unappropriated Fund Balance Remaining After Amendment: 721,936.00

BETHANY CITY COUNCIL

From: Michael Vaughn, Finance Director
Date: 9/5/2023
Subject: Budget Amendment 24-3

BACKGROUND

The City of Bethany has been awarded Federal Grants for sewer projects, a water meter replacement project and wellfield improvements. We have not expended any funds on any of these projects as of the end of FY 23. We will be spending money on these projects this year, so the expense accounts need to be funded.

Budget Amendment 24-3 appropriates the funding for the federal grant projects in Fiscal year 23-24.

RECOMMENDATION

1. Approve Budget Amendment 24-3(attached).

ADDITIONAL COMMENTS



Approval of and authorization to execute Budget Amendment Number BA# 24-3

BUDGET AMENDMENT FORM



Funds: Federal Grant Fund
Amendment #: BA #24-3
Fiscal Year: FY2024

<u>Account #</u>	<u>Account Name</u>	<u>Estimated Revenue</u>		<u>Appropriations</u>	
		<u>Increase</u>	<u>Decrease</u>	<u>Increase</u>	<u>Decrease</u>
Federal Grant Fund					
035-542.0-350	Meter Replacement Project			3,000,000	
035-542.0-340	Sewer Project			3,372,963	
035-542.0-340	Wellfield Project			4,600,000	
035-23115	Unearned Revenue-Grants	10,972,963			
TOTALS		<u>10,972,963</u>	<u>-</u>	<u>10,972,963</u>	<u>-</u>

EXPLANATION: 11 OS Section 17-216 B

The Municipal Budget Act adopted by the City Council allows the City to amend the budget at any time during the year for necessary expenditures incurred that exceed the original budget or when changing circumstances warrant the action.

Budget Amendment 24-3 Appropriates approved grant amounts and matching monies for projects in FY 24.

Date & Signature of Mayor: _____ x _____ Date

Date & Signature of City Manager: _____ x _____ Date

Date Approved by City Council: September 5th, 2023 _____

Federal Grant Fund

Unappropriated Fund Balance Remaining After Amendment: 0.00

BETHANY CITY COUNCIL

From: Michael Vaughn, Finance Director
Date: 9/5/2023
Subject: Budget Amendment 24-4

BACKGROUND

The City of Bethany budgeted the purchase of a sanitation truck in FY 23. The funds were encumbered, and the truck was ordered however the truck was not delivered or invoiced in 2023. These funds need to be re-appropriated this year to pay for the truck.

Budget Amendment 24-4 appropriates the funding for the Sanitation Truck Fiscal year 23-24.

RECOMMENDATION

1. Approve Budget Amendment 24-4(attached).

ADDITIONAL COMMENTS



Approval of and authorization to execute Budget Amendment Number BA# 24-4

BUDGET AMENDMENT FORM



Funds: Capital Improvement Fund
Amendment #: BA #24-4
Fiscal Year: FY2024

<u>Account #</u>	<u>Account Name</u>	<u>Estimated Revenue</u>		<u>Appropriations</u>	
		<u>Increase</u>	<u>Decrease</u>	<u>Increase</u>	<u>Decrease</u>
Capital Improvement Fund					
031-540.0-42022	Sanitation Truck			243,624	
031-25390	Fund Balance	243,624			
TOTALS		<u>243,624</u>	<u>-</u>	<u>243,624</u>	<u>-</u>

EXPLANATION: 11 OS Section 17-216 B

The Municipal Budget Act adopted by the City Council allows the City to amend the budget at any time during the year for necessary expenditures incurred that exceed the original budget or when changing circumstances warrant the action.

Budget Amendment 24-4 Carries over funds appropriated in FY 23 to purchase a Sanitation Truck. The funds werer encumbered and the truck was ordered however the truck was not delivered or invoiced in FY 23.

Date & Signature of Mayor: _____ x _____ Date

Date & Signature of City Manager: _____ x _____ Date

Date Approved by City Council: September 5th, 2023 _____

Capital Improvement Fund

Unappropriated Fund Balance Remaining After Amendment: 798,412.00

BETHANY CITY COUNCIL

From: Michael Vaughn, Finance Director
Date: 9/5/2023
Subject: Budget Amendment 24-5

BACKGROUND

The citizens of the City of Bethany approved the issuance of GO Bonds totaling \$15,000,000 in October of 2022. The city will have interest payments due in FY 24 totaling \$987,093.75
Budget Amendment 24-5 recognizes the ad valorem tax to be received and appropriates that amount to pay the debt service obligation in FY 24.

RECOMMENDATION

1. Approve Budget Amendment 24-5(attached).

ADDITIONAL COMMENTS



Approval of and authorization to execute Budget Amendment Number BA# 24-5

BUDGET AMENDMENT FORM



Funds: Debt Service Fund
Amendment #: BA #24-5
Fiscal Year: FY2024

<u>Account #</u>	<u>Account Name</u>	<u>Estimated Revenue</u>		<u>Appropriations</u>	
		<u>Increase</u>	<u>Decrease</u>	<u>Increase</u>	<u>Decrease</u>
Debt Service Fund					
040-31111	Ad Valorem Tax CY	987,094			
040-599.0-601	Bond Interest Exp.			987,094	
TOTALS		<u>987,094</u>	<u>-</u>	<u>987,094</u>	<u>-</u>

EXPLANATION: 11 OS Section 17-216 B

The Municipal Budget Act adopted by the City Council allows the City to amend the budget at any time during the year for necessary expenditures incurred that exceed the original budget or when changing circumstances warrant the action.

Budget Amendment 24-5 Recognizes Increased Ad Valorem Tax for new GO Bond issues and Appropriates the amount for the Debt Service Payments.

Date & Signature of Mayor: _____ x _____ Date

Date & Signature of City Manager: _____ x _____ Date

Date Approved by City Council: September 5th, 2023 _____

Debt Service Fund

Unappropriated Fund Balance Remaining After Amendment: **630,721.00**

BETHANY CITY COUNCIL

From: Elizabeth A. Gray, City Manager
Date: August 30, 2023
Subject: Consideration and possible approval to appoint Marilyn Wetmore as the City of Bethany's representative to the Metropolitan Library Commission to serve a three-year term expiring July 31, 2026

BACKGROUND

The Metropolitan Library Commission of Oklahoma County is comprised of twenty-seven (27) members who represent each municipality with a library or library extension located within its boundaries for a three-year term. The Mayor of Oklahoma City, an Oklahoma County Commissioner, and the Library's Executive Director complete the commission. The Library Commission meets monthly at a different library location around Oklahoma County.

The last term expired July 31, 2023. The Mayor desires to nominate Ms. Marilyn Wetmore to serve a three-year term expiring July 31, 2026. Ms. Wetmore has previously served as the secretary on the Cemetery Task Force.

Ms. Wetmore has completed a Board Application form and is willing and eager to serve the citizens of Bethany on this commission.

RECOMMENDATION

1. Approve Marilyn Wetmore as the City of Bethany's representative on the Metropolitan Library Commission for a three-year term expiring July 31, 2026.

ADDITIONAL COMMENTS

A circular stamp containing the handwritten initials "dg" in blue ink.

City of Bethany BOARD APPLICATION FORM

Choose the board or committee you are applying for:

Board of Adjustment
 Bethany Economic Development Authority
 Planning and Zoning Commission
 Other: Metro Library Board

Name: <u>Marilyn J. Wetmore</u>		In which Ward do you reside:	
Street Address: <u>7701 NW 25th Terrace</u>			
City: <u>Bethany</u>	State: <u>OK</u>	Zip Code: <u>73008</u>	
Home Phone: [REDACTED]	Cell Phone: [REDACTED]		
Email Address: [REDACTED]			
Occupation: <u>Retired teacher, media director</u>			

Serving on a board or commission can be time consuming. Does your schedule allow attendance at regularly scheduled meetings?	<input checked="" type="checkbox"/> Yes <input type="checkbox"/> No
If appointed, are you willing to comply with the City of Bethany Conflict of Interest Policy as stated in Section 7.5 (c) of the City Charter? <i>c) Any member of the Council or any board, commission, or other authority who has a direct personal or private interest in any question before the body of which he is a member shall abstain from voting thereon. Violation of this section shall constitute cause for removal from office for members of any board, commission, or other authority of the City government. Provided, however, a violation of this section shall not affect the validity of any action taken by the City Council or any other board or commission of the City.</i>	<input checked="" type="checkbox"/> Yes <input type="checkbox"/> No

Education and Hobbies		
Level	Certificate / Degree / Major	Name of School
High School	<u>H.S. Diploma</u>	<u>Comanche High School, Comanche,</u>
College	<u>UCO; BA, M Educ,</u>	<u>Library Science Certificate OK</u>
Trade or Business School		

Hobbies: Volunteer at Heart & Hand Thrift Store; ROC Food Pantry;
Serve as treasurer for exercise class, the Cube, Council Rd.
Active at Calvary Church of the Nazarene Baptist Church

It is suggested that you include a cover letter and resume with your application.

I understand that this application does not guarantee an appointment to any board or committee. Appointments are approved by a City Council majority vote and this application is subject to the Open Meeting Act and Open Records Act.

Signature: Marilyn J. Wetmore Date: 08/30/23

RESUME

**Marilyn J. Payne Wetmore
7701 NW 25th Terrace
Bethany, OK 73008**

EDUCATION

**Central State College, Edmond Ok.....Bachelor of Arts Degree
May, 1966**

**University of Central Oklahoma.....Master of Education, 1970
Library Science Certification, 1980**

EMPLOYMENT HISTORY

**Teacher of English/Speech for high school and junior high with
Harrah Public Schools, Sept. 1966-Jan. 1970**

Social Work in Lincoln County, Chandler office of DHS: 1971-72

**Teacher/ Librarian for Vashti Girls School in Thomasville, Georgia
June, 1972-July, 1975**

Teacher/Media Director for Bethany Public School, 1982-2000

At the suggestion of the Director of the OBU university library, I served as a reference librarian for one semester in 2002. The commute was too much. I also had the chance to teach aspiring teachers a beginning media class at SNU in 1990 under the direction of Dr.Tullis.

In 2005, we moved to Norman to assist in the rearing of our first of two grandsons, which included a priceless education in the growth and development of the male species. Regular visits to the Pioneer Library System were also helpful.

We moved back to the Bethany area in 2014 and I have been involved in church work and volunteer assignments, as well as serving on the committee which brought changes to the Bethany cemetery.

REFERENCES

Ron Cole, Associate Pastor/Chaplain at Calvary Church of the Nazarene

Marilyn Stark, Representative in Oklahoma State House

BETHANY CITY COUNCIL
BETHANY PUBLIC WORKS AUTHORITY

From: Elizabeth A. Gray, City Manager
Date: August 23, 2023
Subject: Consideration and possible approval to acknowledge Oklahoma Water Resources Board (OWRB) grant award and open a bank account to receive the OWRB grant in the amount of \$100,000 to pay for a portion of the NW 23rd Street and Council Road emergency.

BACKGROUND

On July 8, 2023, the City of Bethany experienced a significant rain event that washed the soil from underneath a 12-inch concrete water line. The line collapsed at the very busy 23rd and Council intersection. The drainage pipe both upstream and downstream of this break had to be replaced to prevent further occurrences. The City of Bethany did not have funding for this repair identified in the current budget.

July 13, 2023, an emergency meeting was held where the City Council ratified emergency expenditures for the water line collapse and approved evaluating, repairing and replacing the drainage structure. On July 18, 2023, Resolution 1679 was approved by the Council giving approval to the City Manager to apply for Emergency Grant Funding from the Oklahoma Water Resources Board (OWRB) to help defray costs associated with the emergency repairs. On August 16, 2023, The City Manager was notified that the OWRB Emergency Grant Funding Application was approved for \$100,000.

Total costs for this project are as follows:

Initial water line repair	\$ 28,763.53
Engineering and design approx	\$ 25,000.00
Purchase of water from Oklahoma City	\$ 48,837.91
Storm line excavation, replacement, and paving	<u>\$ 227,395.23</u>
Subtotal	\$ 329,996.67
-OWRB Emergency grant	<u>\$ 100,000.00</u>
Total	\$ 229,996.67

Per the Emergency Grant Agreement, a special and separate federally insured bank account must be created and maintained to receive the funds.

RECOMMENDATION

1. Acknowledge Oklahoma Water Resources Board (OWRB) grant award and open a bank account to receive the OWRB grant in the amount of \$100,000 to pay for a portion of the NW 23rd Street and Council Road emergency.

ADDITIONAL COMMENTS



OKLAHOMA WATER RESOURCES BOARD

EMERGENCY GRANT APPLICATION NO. FAP-24-0002-G

EMERGENCY GRANT AGREEMENT between City of Bethany, Oklahoma County and Oklahoma Water Resources Board

I, Ms. Shannon Lloyd, duly authorized Mayor of the City of Bethany, Oklahoma County (hereinafter "Applicant"), do hereby accept and acknowledge said grant according to the terms of this Emergency Grant Agreement. Receipt of the subject grant funds shall be acknowledged by separate receipt instrument at the time the same shall be received by an authorized representative of said applicant.

In accepting said grant, applicant duly acknowledges and agrees that in all regards and respects, applicant must and shall comply with the requirements of all applicable federal and state statutory provisions and all Oklahoma Water Resources Board (the "Board") rules, regulations and Emergency grant policies. Without limiting the generality of the foregoing, the applicant agrees as follows:

1. **Description of approved project.** This grant has been approved by the Board for applicant's project which shall be to repair the waterline, install an arched, reinforced concrete pipe from the junction box to the damaged joint of the stormwater system, install a concrete collar around the new arch pipe and the existing corrugated metal pipe, fill in the washout caused by the breach as well as other related construction and appurtenances (the "Project"), as provided in the Board's Order Approving Emergency Grant Application attached hereto as "**Attachment 1**" and incorporated by reference herein.
2. **Determination of amount of grant.** The amount of this grant shall not exceed the amount of One hundred thousand dollars only.
3. **Creation and maintenance of separate account.** As a prerequisite to receiving grant money from the Board, applicant shall establish to the satisfaction of the Board staff, a special and separate federally insured account entitled "Oklahoma Water Resources Board Emergency Grant Account" (hereinafter referred to as "Emergency Grant Account") through which the grant proceeds shall be administered and accounted for by the applicant. Prior to the Board's release of any grant money, applicant shall file a letter with the Board identifying the account number for the Emergency Grant Account. Upon receipt of grant money from the Board, applicant shall deposit the grant money in this Emergency Grant Account and shall expend money from the account only as permitted in this Emergency Grant Agreement and Board rules.
4. **Expenditure of money in grant account only for authorized Project purposes.** Applicant shall disburse or expend money from the Emergency Grant Account only toward eligible and authorized purposes for the Project approved by the Board. Authorized Project costs include project construction labor pursuant to contract (except force account labor), construction materials, soil testing, engineering, and inspections. Any amount of grant money expended from the Emergency Grant Account for unauthorized purposes shall be repaid by the applicant to the Board, together with payment of interest accrued from the date of the expenditure at the maximum rate allowed by law, no later than thirty (30) days after the date of written demand from Board staff. Applicant shall maintain proper books, records, and supporting documentation (such as invoices, billing statements, and canceled checks drawn on the Emergency Grant Account) showing to the satisfaction of the Board staff the amounts and purposes of all expenditures from the Emergency Grant Account, and shall make the same available for inspection and examination by the Board. Any disbursement of grant money without adequate supporting documentation shall be deemed to be an unauthorized expenditure of grant money which applicant shall repay to the Board with interest as provided above. The applicant shall direct to the Board staff any and all questions regarding whether an expenditure is authorized prior to making the expenditure.

OWRB EMERGENCY Grant Agreement
OWRB EMERGENCY Grant No. FAP-24-0002-G

5. **Time limit to provide bid tabulation; expiration of approval.** Pursuant to Board Rule 785:50-6-2(a), an emergency will be deemed no longer to exist, and a grant application based thereon will not be funded, after the passage of 180 days following the date the emergency the date last occurred, unless the Board finds, upon evidence satisfactory to the Board, that the emergency continues to exist as the date of funding. Applicant shall furnish the Board an acceptable quote or copy of a negotiated contract for completion of the Project on or before February 11, 2024 as a condition to receiving grant funds. If requested by applicant and determined by the Board to be necessary and appropriate, the Board or its staff may permit additional time, but no later than August 14, 2024, to file an acceptable bid tabulation. No additional time beyond February 11, 2024 shall be effective unless expressly approved by the Board staff in a letter, which specifies the new deadline for filing the bid. Regardless of any approval of additional time, the approval of this grant shall not extend past August 14, 2024; if a bid tabulation is not filed on or before that date, then the approval of this grant shall expire and no grant funds will be released to applicant.

6. **Return of unexpended grant money.** The applicant shall return to the Board any unexpended grant money, including any unexpended contingencies funds, within thirty (30) days after completion of the construction of the Project or within thirty (30) days from the applicant's receipt of all invoices, whichever is later.

7. **Prohibition against modifying utility rates which produced favorable priority rating.** If applicant has raised water and/or sewer rates resulting in an advancement in position of priority for assistance, applicant shall not modify those rates after receipt of the grant without the prior written consent of the Board, which consent shall not be withheld unless Board staff find such modification, if in effect at the time the application was approved, would have changed the applicant's position of priority relative to other grant applications pending at the time.

In consideration of the applicant's agreement to these terms and conditions, applicant has entered into and signed this Emergency Grant Agreement this ____ day of _____, 20__.

City of Bethany, Oklahoma County, Oklahoma

By: Shannon M. Lloyd
Ms. Shannon Lloyd, Mayor

ATTEST:
By: Linda Warner
Title: Executive Assistant

(BOARD SEAL)

BETHANY CITY COUNCIL

From: Elizabeth A. Gray, City Manager
Date: August 28, 2023
Subject: Consideration and Possible Approval of Interlocal Cooperation Agreement with Bethany Public Schools to Power wash and add Championship team names to the Water Storage Tank

BACKGROUND

Bethany Public Schools leases some of our property at McFarland Park for athletic facilities. Some years ago, the concrete water storage tank located on the north side of the water treatment works was painted. Bethany Public Schools also painted their logo on the tank.

Normally, the City does not paint this type of water tank, as it is not necessary to help preserve the external surface.

Bethany Schools would like to power wash and add two championship teams to the tower. The 2019 Game Day Cheer team and the 2023 Girls Basketball Champions.

This agreement requires Bethany Schools to be responsible for washing and painting the water tank. The City of Bethany is very proud of the accomplishments of these two teams!

Staff recommends approval.

RECOMMENDATION

1. Approve the Interlocal agreement as presented.

ADDITIONAL COMMENTS



INTERLOCAL GOVERNMENTAL COOPERATION AGREEMENT

THIS AGREEMENT is made and entered into this ____ day of _____, 2023 by and between Bethany Public Schools, hereinafter, referred to as "BPS", and the City of Bethany, hereinafter referred to as "Bethany" the respective governing body of each such entity by appropriate action witnesseth:

WHEREAS, Bethany owns a certain water storage tank near NW50th and Council Road; and

WHEREAS, BPS desires to power wash and paint two championship teams to said water storage tank; and

WHEREAS, BPS desires to clean and paint the championships of the 2019 Game Day Cheer Championship and the 2023 Girls State Championship Basketball Team on the water storage tank.

NOW, THEREFORE, for good and valuable consideration herein contained, IT IS AGREED AS FOLLOWS:

1. TERMS OF AGREEMENT

The term of this agreement shall be from September 3, 2023 to June 30, 2024. Either party may terminate this agreement upon thirty (30) days written notice to the other party.

11. STATEMENT OF SERVICES

BPS agrees to power wash and paint said water tank using paint agreed to by Bethany. BPS agrees to contract for the purchase of the paint and labor to accomplish the project.

111. BPS RESPONSIBLE FOR SAFETY OF WORKERS AND CONTRACTORS

BPS agrees to be responsible for the safety of the workers and contractors doing the work on the project.

BPS further agrees to require worker's compensation and liability insurance for all contractors working on the project and to furnish acceptable proof of insurance to Bethany.

IX. HOLD HARMLESS CLAUSE

To the extent allowed by law, BPS hereby agrees to indemnify and hold Bethany harmless for any claim, action or cause of action including the cost of litigation and attorney fees arising under this agreement.

IT IS FURTHER AGREED that BPS shall reimburse Bethany any expenses resulting from the repair of any damages caused by BPS staff or contractors to the water storage tank.

APPROVALS

APPROVED this ____ day of _____, 2023, by the City of Bethany.

Nikki Lloyd, Mayor
City of Bethany

Attest:

Michael Vaughn, City Clerk

Approved as to form and legality:

Ray Jones, Jr., City Attorney

APPROVED this ____ day of _____, 2023, by Bethany Public Schools.

Dr. Rueben Bellows, Superintendent
Bethany Public Schools

Attest:

Bethany Public Schools

Approved as to form and legality:

Bethany Public Schools

BETHANY CITY COUNCIL

From: Elizabeth Gray, City Manager
Date: August 31, 2023
Subject: Request Permission to Advertise for Bids for the Cecil Mendenall Park Restroom
(G.O. Bond Proposition 2-F)

BACKGROUND

On August 23, 2022, citizens of Bethany passed General Obligation Bond, Proposition 2-F for improving Cecil Mendenall Park including constructing restroom facilities.

TEIM Design now requests permission to advertise for bids.

RECOMMENDATION

1. Approve permission to advertise for bids for G. O. Bond Proposition 2-F Cecil Mendenall Park restroom facilities.

ADDITIONAL COMMENTS

Funding sources to include 2016 G. O. Bond.

A circular stamp containing the handwritten initials "dg" in blue ink.

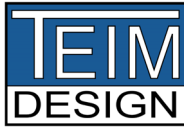

TRANSPORTATION • ENVIRONMENTAL • INFRASTRUCTURE • MUNICIPAL

August 31, 2023

City of Bethany
Ms. Elizabeth Gray
6700 NW 36th Street
Bethany, Oklahoma 73008

Re: Request Permission to Advertise for Bids for the Cecil Mendenall Park Restroom (G.O. Bond Prop. 2-F)

Dear Ms. Gray,

We are requesting permission to advertise for bids the Cecil Mendenall Park Restroom (G.O. Bond Prop. 2-F). This project will provide for a new restroom facility.

The project schedule is as follows:

Advertise for bids on October 20, 2023, and October 27, 2023, in the Journal Record.
Pre-bid meeting November 7, 2023 at 10:30 AM.
Open bids November 14, 2023 at 10:00 AM.
City Council consider award of the project on November 21, 2023.

Should you need additional information please feel free to contact me.

Sincerely,

A handwritten signature in black ink, appearing to read 'S Manek', written in a cursive style.

Steve Manek, PE

Attachments: Project location map and preliminary floor plan and elevation

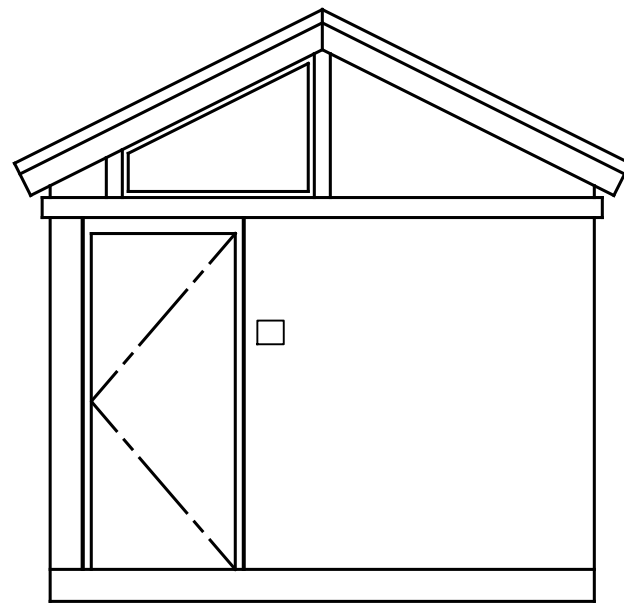

A ENTRY ELEV. TYPE 1

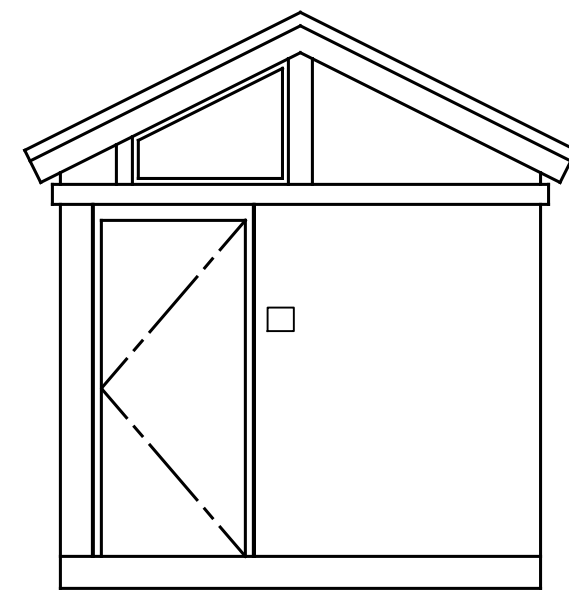

B ROMTEC MODEL 2003
ENTRY ELEV. TYPE 2

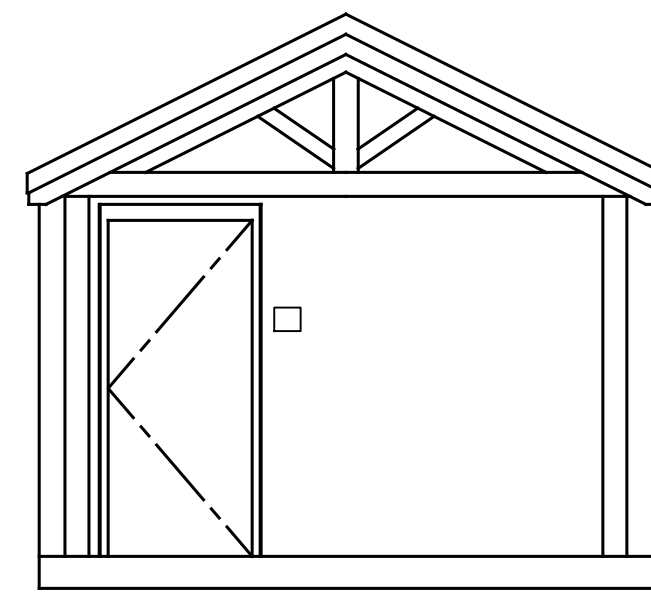

C ENTRY ELEV. TYPE 3

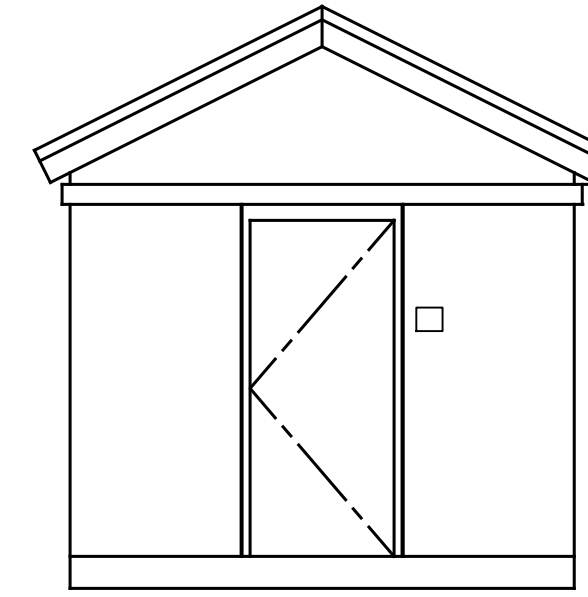

D ENTRY ELEV. TYPE 4

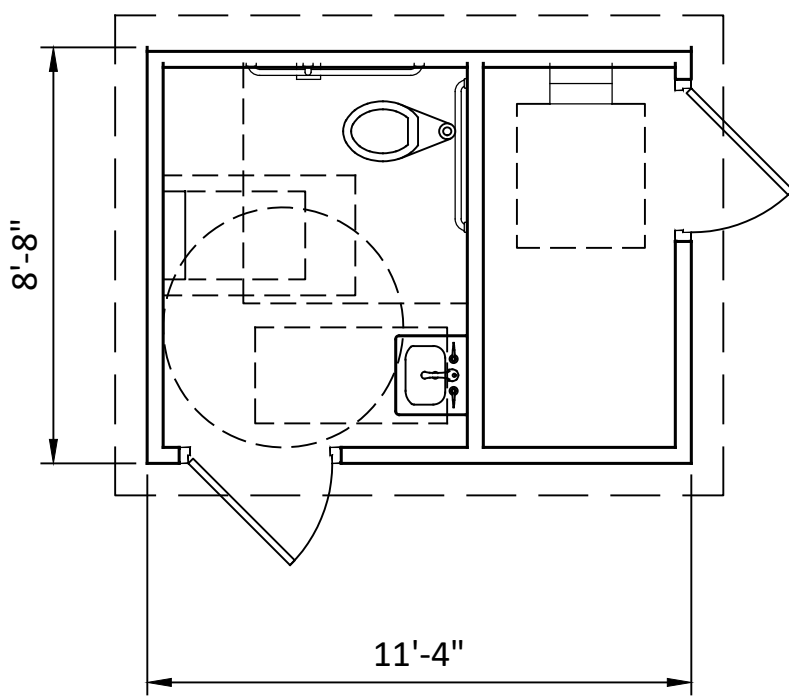

E PUBLIC RESTROOM CO. PS-111
ENTRY ELEV. TYPE 1

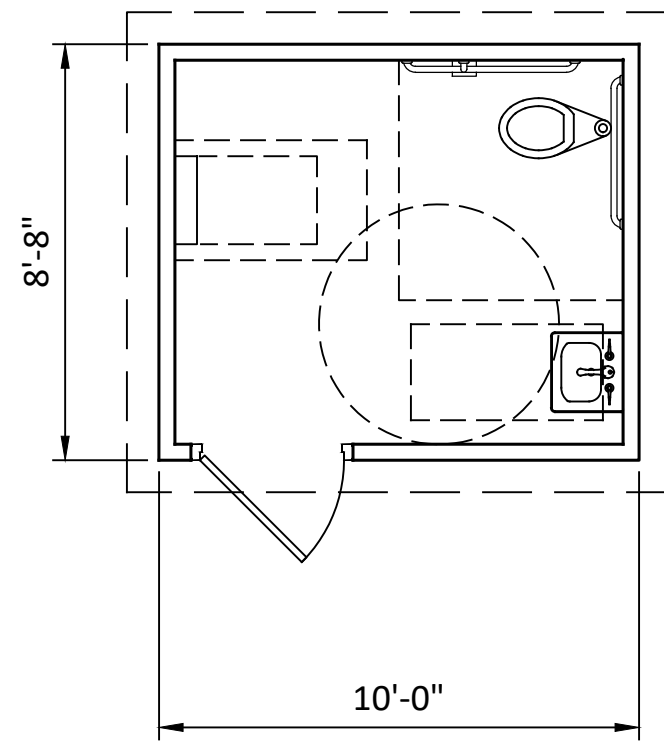

F ROMTEC MODEL 2033
ENTRY ELEV. TYPE 2

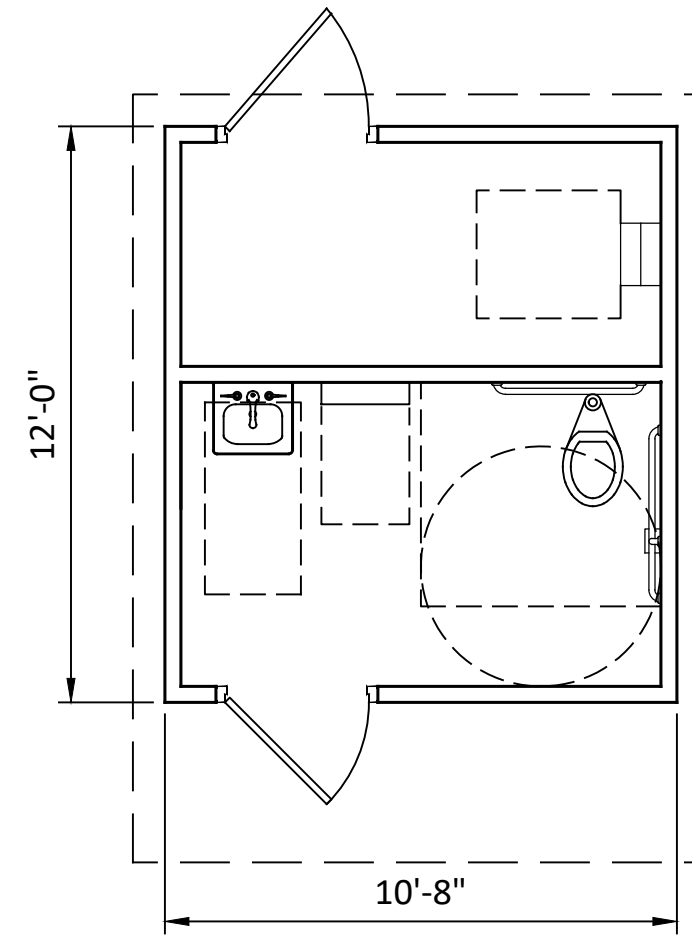

G COREWORTH MODEL W101CE
ENTRY ELEV. TYPE 3

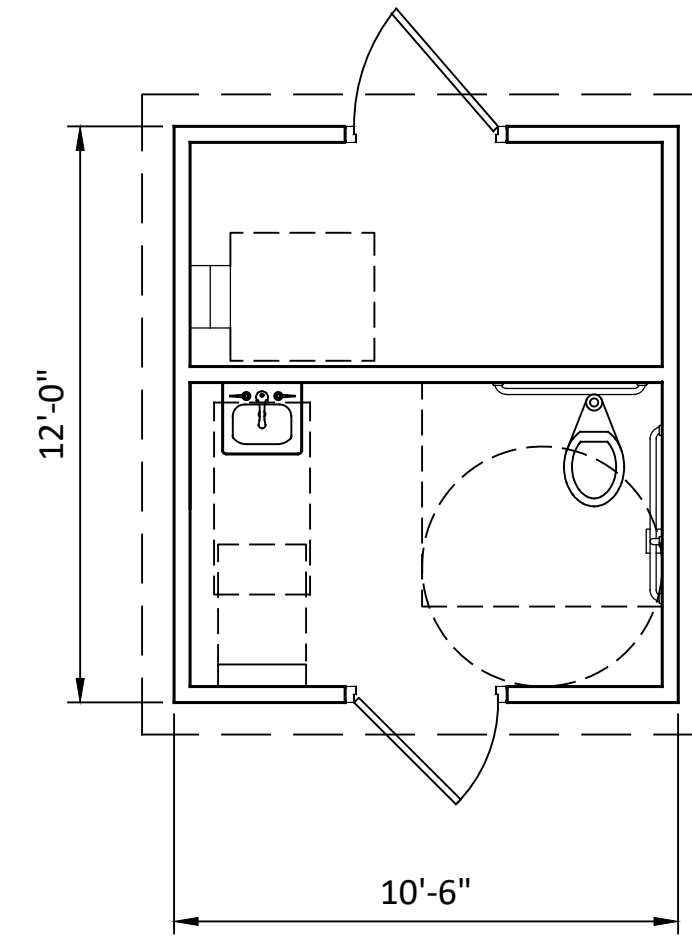

H LBFOSTER CTX MODEL ORARK 1
ENTRY ELEV. TYPE 4

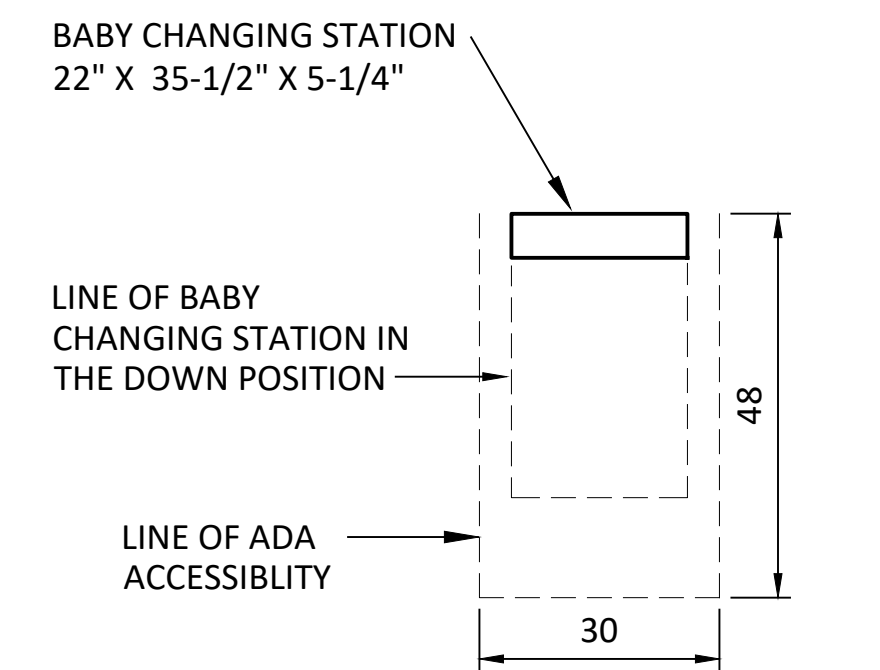
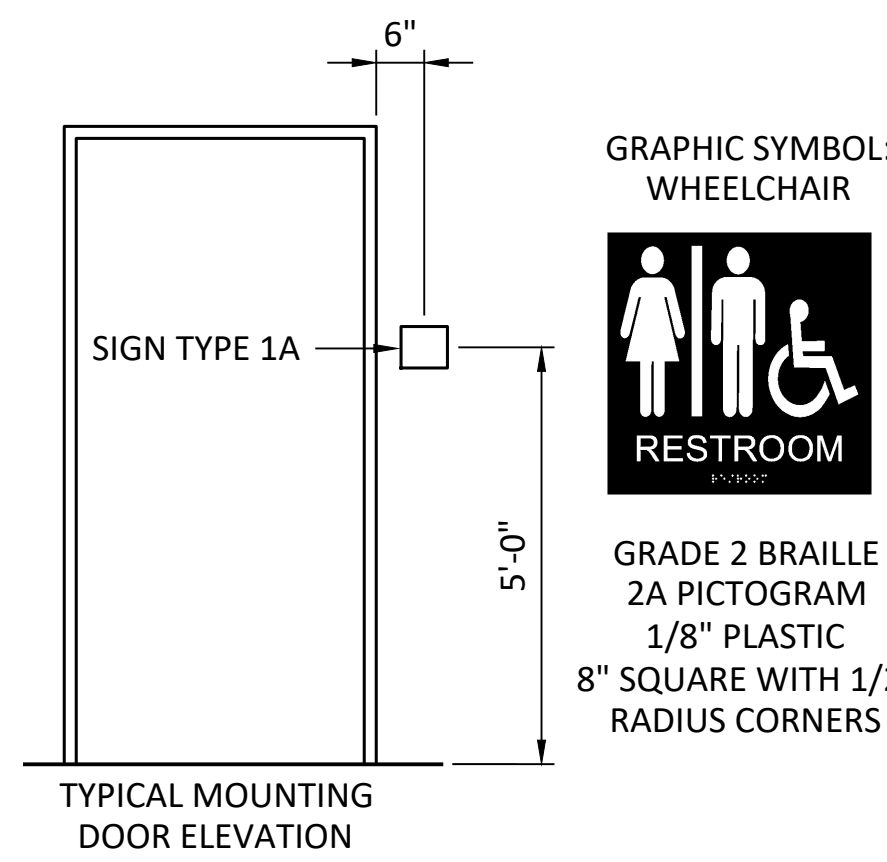
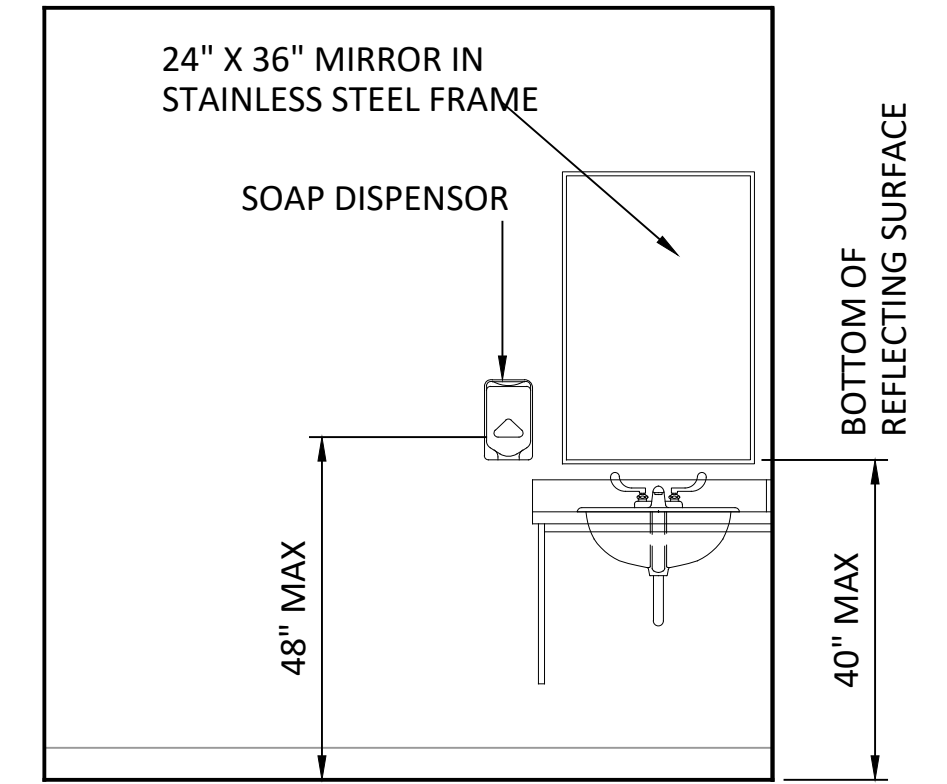
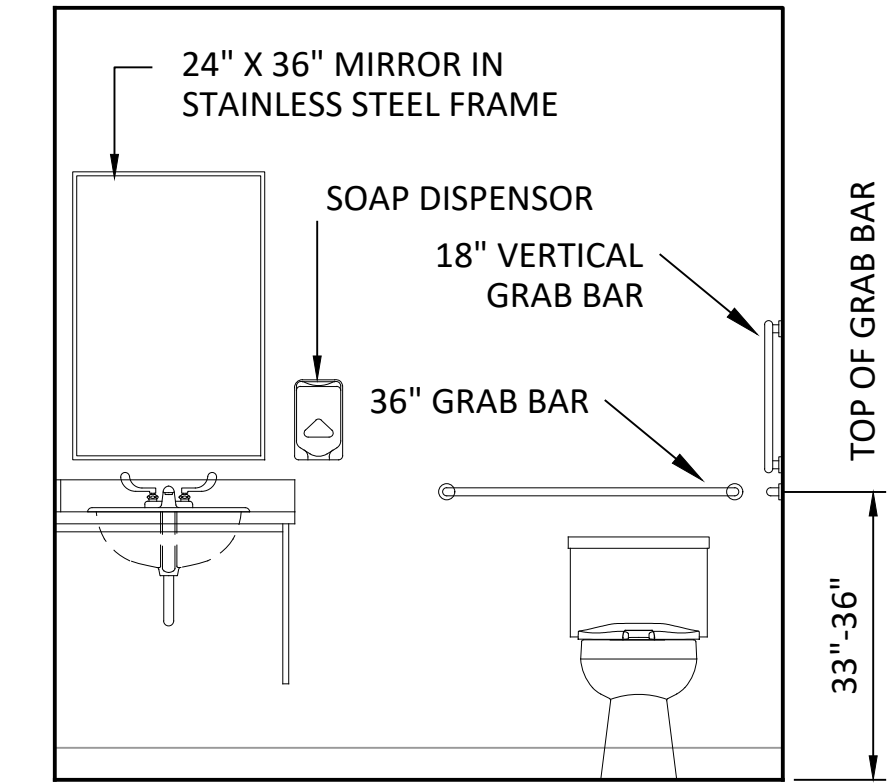
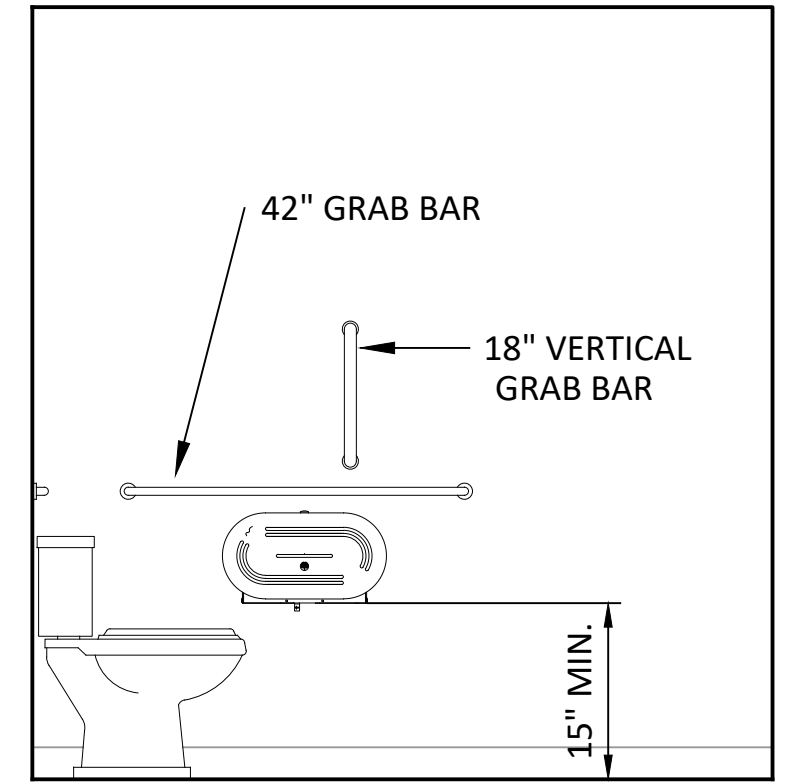
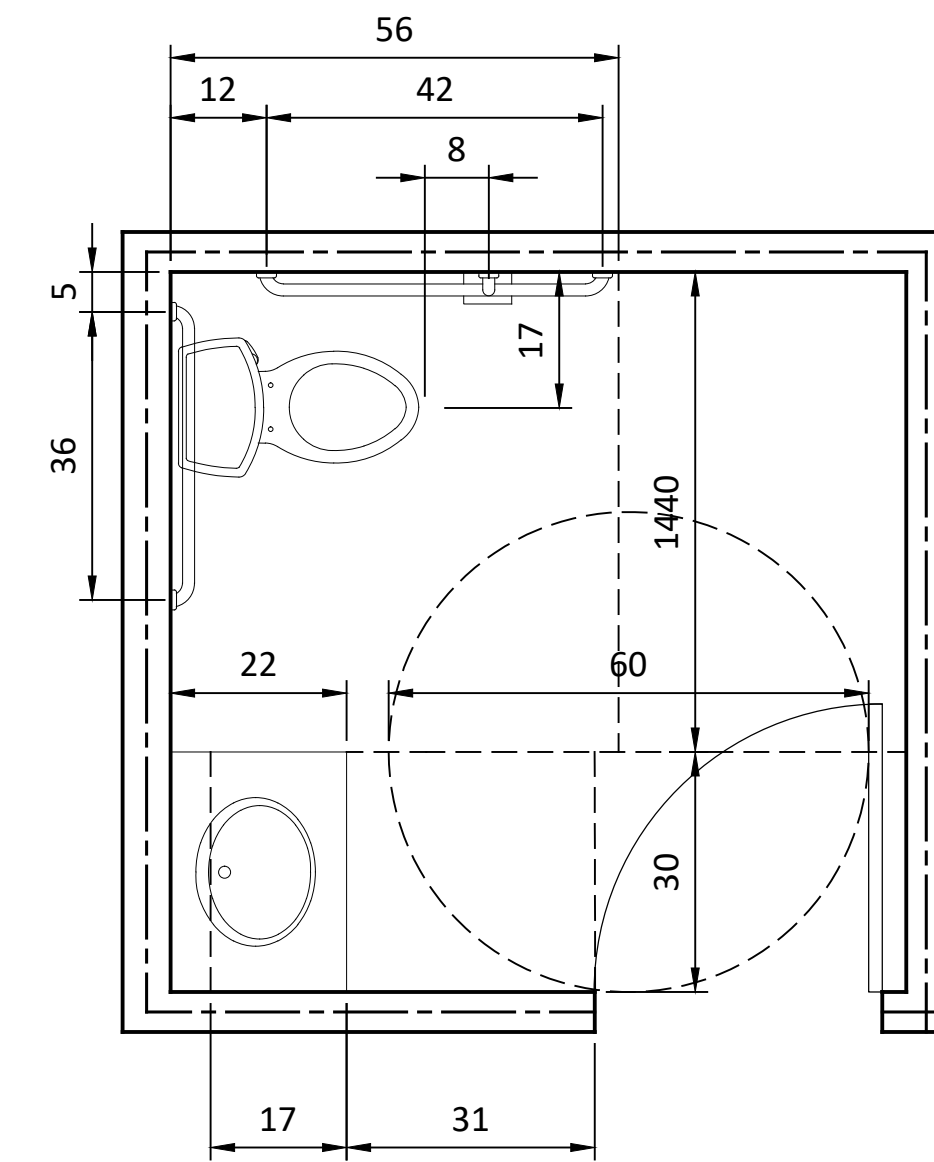

- SCOPE:**
- A DESIGN, BUILD, AND INSTALLATION FIRM OF PREFABRICATED, MODULAR CONSTRUCTION PUBLIC RESTROOMS.
 - THE BUILDING IS TO BE PREFABRICATED, COMPLETE INCLUDING PLUMBING AND ELECTRICAL HOOKUPS.
 - DELIVERED TO THE SITE, OFF LOADED, AND SET UP AT SITE.
 - FINAL CONNECTION TO UTILITIES.
 - PROVIDES A ONE YEAR WARRANTY.
 - NOTE THAT THE 4 FLOOR PLANS AND ELEVATIONS THAT ARE SHOWN ABOVE ARE EXAMPLES FOR REFERENCE. IT IS NOT THE INTENT TO LIMIT A COMPANIES PRODUCT. THEY ARE INTENDED TO SET A STANDARD FOR BIDDING.
- BASE BID INSTALLED COST:**
- ONE SINGLE USER FULLY ACCESSIBLE FLUSH RESTROOM TO MEET ALL LOCAL BUILDING CODES AND TO BE A.D.A. COMPLIANT..
- STANDARD FEATURES:**
- TEXTURED CONCRETE OR MASONRY WALLS COMPOSITION ROOFING
 - DOOR OPENER: NON-LOCKING ADA HANDLE PRIVACY ADA LATCH PULL HANDLE/PUSH PLATE, DEADBOLT.

- ACCESSIBLE SIGNAGE: MEN/WOMEN/UNISEX
 - VITREOUS CHINA FIXTURES
 - STAINLESS STEEL TOILET PAPER HOLDER 1-ROLL
 - INTERIOR AND EXTERIOR LIGHTS
- OPTIONAL FEATURES AND INSTALLED COST:**
- WALL TEXTURE- SPLIT FACE BLOCK
 - STANDING SEAM METAL ROOFING
 - BABY CHANGING TABLE
 - INSULATION AND HEATER
 - 4-GALLON WATER HEATER
 - PAPER TOWEL DISPENSER
 - TOILET PAPER HOLDER, 2-ROLL STAINLESS STEEL 3-ROLL STAINLESS STEEL
 - SANITARY NAPKIN DISPOSAL RECEPTACLE
 - STAINLESS STEEL WATER CLOSET & LAVATORY
 - STAINLESS STEEL URINAL
 - ELECTRIC HAND DRYER
 - ELECTRONIC FLUSH VALVE
 - SKYLIGHT IN RESTROOM

REV. NO.	DATE	DRWN	CHKD	REMARKS

SCALE: AS SHOWN
DATE: DATE
DRAWN BY: ---
CHECKED BY: ENGINEER



CITY
BETHANY CECIL MENDENALL PARK
UNISEX RESTROOM

ARCHITECTURAL
PERFORMANCE DESIGN AND
SPECIFICATION

XX-###
SHEET NO.
SHEET A1 OF 1

EXHIBIT "A"

Topographic Survey Limits



BETHANY CITY COUNCIL

From: Robert Ray Jones, Jr., City Attorney
Date: August 31, 2023
Subject: Charter Review Committee recommendations

BACKGROUND

The Charter Review Committee was convened to examine the Charter and make recommendations to the City Council pursuant to Charter Section 9-2. As a result of the Charter Review, the Committee make six recommendations to the City Council.

1. **Section 2-2 COUNCIL QUALIFICATIONS:** The committee vote on this item was split 3-2. There was debate regarding whether to change the number of council members. The two competing thoughts were (1) the current number of council members was functioning and provided more than adequate representation among the four wards; and (2) the number of council members should be reduced to make regular meetings more efficient, to reflect the number of members in other similar sized cities, and to provide a single point of contact for constituents in each of the wards.
2. **Section 2-6 COUNCIL: POWERS:** The committee vote on this item was unanimous. The City of Bethany is formed as a council-manager form of government. Our Charter specifically grants the City Manager the sole power to appoint and remove administrative heads, officers and employees of the city for the good of the service at Charter Section 3-3. “Good of the Service” is a legally fancy way to say that the city’s employment relationships are at-will – meaning either the City or the employee may terminate the employment contract at any time, for any reason that is not contrary to Oklahoma law. The Charter at section 2-6 authorizes the creation of a personnel board, which is a creature of just cause employment – meaning you cannot terminate the employment of any person without providing due process procedures and hearings, and termination may not occur without adequate and sufficient cause and reason. Personnel boards and departments are part and parcel to Strong Mayor-Council forms of government in Oklahoma, as established at Title 11 Oklahoma Statutes section 11-118. The Charter provisions at 2-6 and 3-3 cannot co-exist. Since the State of Oklahoma is an “at-will” employment state and City-Manager form of government is matched with “at-will” employment, the Committee unanimously voted to change Section 2-6, which authorized the City of Bethany to create a personnel board.
3. **Section 2-11 MAYOR AND COUNCIL REMOVAL:** The committee vote on the changes to this Charter section was unanimous. A new section was added to this charter provision creating a Recall procedure that could be utilized by the citizens of the City of Bethany. The discussion of the elements of the recall provision occurred over several weeks in part to tune the align the procedure to the city’s population and voter activity. In order to begin the process for recall, there first must be an affidavit filed by a person or persons representing 100 qualified electors. The process provides for the petition to identify the reason or reasons that the incumbent should be recalled and an opportunity for the incumbent to respond. In order for a recall election to

be called, the petition must contain 33 1/3 per cent of the total number of votes cast for the Councilmember or for the city-at-large for Mayor.

4. Section 4-3 PURCHASES AND SALES. The committee vote on the changes to this Charter section was unanimous. Currently, the City's charter requires that any surplus or obsolete supplies, materials, and equipment must be sold through competitive bidding. Oftentimes, this results in items being sold through third-party auctioning services such as e-bay. Unfortunately, this bidding process often generates sales less than market value. The Oklahoma Supreme Court has held that municipalities may transfer supplies, materials, and equipment for other property and/or services. Our Charter currently does not permit this.
5. Section 7-5 CONFLICT OF INTEREST. The committee vote on the changes to this Charter section was unanimous. The committee felt subpart (c) could use some further minor definition. Similar provisions were examined from all of the states, and the following language was added to demonstrate what could be a direct personal or private interest as stated by the Charter: "including financial and other interests, or engages in a business transaction or professional activity, or incurs any obligation of any nature that is in substantial conflict with the proper discharge of the officer's duties"
6. Section 7-9.1 REMOVAL/OUSTER OF COUNCILMEMBERS AND MAYOR. The committee vote on the changes to this section were unanimous. Additional language was added to this Charter provision so as to eliminate any confusion with the creation of the Recall provision in the newly proposed Section 2-11 (B).

Our ordinances at Section 32.096 (D) state: the Charter Review Board "may prepare and propose any amendments to the Charter to be delivered to the City Council for approval to submit to the people at a general or special election." Before any of these proposed amendments may be placed on a general or special election, the Council will have to approve the changes. Any proposed charter provision not approved by the Council could still be explored by the citizens by petition and referendum.

The Council participated in one special meeting to discuss the proposals submitted by the Charter Review Committee. Some changes were considered with respect to the recall provision for the charter with respect to number and language to be included regarding the form of petition. However, there was no action taken on any of the items by council. Chris Powell inquired about a course of action that could be taken with the charter review committee's recommendations and requested these matters be placed on the agenda for discussion and possible action.

RECOMMENDATION

1. The City Attorney recommends that sections 2-6 be approved because section 2-6 is in conflict with section 3-3 of the Charter and our form of government.
2. The City Attorney recommends that sections 2-11 and 7-9.1 be resubmitted to the committee for changes.
3. The City Attorney has no legal opinion on the Section 2-2, 4-3, and 7-5 other than the proposed changes are legally acceptable.



NOTICE: On Monday, August 14, 2023, at or before 4:59 p.m., agenda was posted at the front doors of City Hall, on the bulletin board in the lobby of City Hall, and on the City of Bethany website: cityofbethany.org. The City of Bethany encourages participation from all its citizens. If participation at any public meeting is not possible due to a disability, notification to the City Clerk at least 48 hours prior to the scheduled meeting is encouraged to make the necessary accommodations. The City may waive the 48-hour rule if signing is not the necessary accommodation.

BETHANY PUBLIC WORKS AUTHORITY MEETING

BETHANY CITY HALL

TUESDAY, AUGUST 15, 2023

6:30 P.M.

MEMBERS PRESENT:	Nikki Lloyd	Chairman
	Jeff Knapp	Vice-Chairman
	Chris Powell	Trustee
	Kathy Larsen	Trustee
	Brian Magirowsky	Trustee
	Ken Smart	Trustee
	Peter Plank	Trustee
	Steve Palmer	Trustee
MEMBERS ABSENT:	Marilyn McPhail	Trustee
OTHERS PRESENT:	Elizabeth Gray	City Manager
	Ray Jones	City Attorney
	Michael Vaughn	City Clerk/Treasurer
	Lesa LaMar	Deputy City Clerk
	Troy Rhodes	Architect
	(See Roster)	

Chairman Lloyd called the Bethany Public Works Authority meeting to order at 7:30 P.M.

ITEM NO. 1 on the agenda was **CONSENT DOCKET:**

- A. APPROVAL OF MINUTES FROM AUGUST 1ST, 2023, REGULAR MEETING.**
- B. APPROVAL OF CLAIMS: THESE CLAIMS HAVE BEEN FOUND TO BE IN ORDER BY STAFF AND PROPER AS TO FORM AND PROCEDURE AND ARE RECOMMENDED FOR PAYMENT. A COPY OF THE CLAIMS.**

Motion was made by Trustee Magirowsky, seconded by Vice-Chairman Knapp to approve the Consent Docket. Yes Votes: Larsen, Palmer, Magirowsky, Lloyd, Powell, Smart, Plank, Knapp. No Votes: None. Motion passed.

ITEM NO. 2 on the agenda was **DISCUSSION AND POSSIBLE ACTION TO APPROVE SOUTHWEST WATER WORKS LLC PAY APPLICATION #1 IN THE AMOUNT OF \$208,311.25 FOR 18607 CDBG 22 WATERLINE REPLACEMENT PROJECT. (ELIZABETH GRAY, CITY MANAGER)**

Motion was made by Trustee Larsen, seconded by Trustee Magirowsky to approve Southwest Water Works LLC pay application #1 in the amount of \$208,311.25 for 18607 CDBG 22 Waterline Replacement Project. Yes Votes: Larsen, Palmer, Magirowsky, Powell, Smart, Plank, Lloyd, Knapp. No Votes: None. Motion passed.

ITEM NO. 3 on the agenda was **CONSIDERATION AND POSSIBLE APPROVAL OF AMENDMENT NO. 1 TO THE CDBG WATERLINE REPLACEMENT PROJECT ON HOLLOWAY AVENUE BETWEEN NW 36TH AND NW 32ND STREETS IN THE AMOUNT OF \$28,115 AND AUTHORIZE THE MAYOR TO SIGN THE DOCUMENT. (ELIZABETH GRAY, CITY MANAGER)**

Motion was made by Trustee Larsen, seconded by Trustee Magirowsky to approve Amendment No. 1 to the CDBG Waterline Replacement Project on Holloway Avenue between NW 36th and NW 32nd Streets in the amount of \$28,115 and authorize the mayor to sign the document. Yes votes: Magirowsky, Lloyd, Knapp, Larsen, Smart, Palmer, Plank, Powell. No votes: None. Motion approved.

ITEM NO. 4 on the agenda was **CONSIDERATION AND POSSIBLE APPROVAL TO GIVE TEIM DESIGN PERMISSION TO ADVERTISE FOR CONCRETE PAVING, ASPHALT PAVING AND DRAINAGE REPAIRS ON CALL CONTRACT. (ELIZABETH GRAY, CITY MANAGER)**

Motion was made by Trustee Larsen, seconded by Trustee Magirowsky to approve to give TEIM Design permission to advertise for Concrete Paving, Asphalt Paving and Drainage repairs on call contract. Yes Votes: Larsen, Palmer, Magirowsky, Powell, Smart, Plank, Lloyd, Knapp. No Votes: None. Motion passed.

ITEM NO. 5 on the agenda was **CONSIDERATION AND POSSIBLE APPROVAL TO GIVE TEIM DESIGN PERMISSION TO ADVERTISE FOR WATER AND SANITARY SEWER REPAIRS ON CALL CONTRACT. (ELIZABETH GRAY, CITY MANAGER)**

Motion was made by Trustee Larsen, seconded by Trustee Magirowsky to approve to give TEIM Design permission to advertise for Water and Sanitary Sewer repairs on call contract. Yes Votes: Larsen, Palmer, Magirowsky, Powell, Smart, Plank, Lloyd, Knapp. No Votes: None. Motion passed.

ITEM NO. 6 on the agenda was **NEW BUSINESS (AS DEFINED BY THE OKLAHOMA OPEN MEETING ACT § 311 (A) (9) AS "MATTERS NOT KNOWN ABOUT OR WHICH**

COULD NOT HAVE REASONABLY BEEN FORESEEN PRIOR TO THE TIME OF POSTING THE AGENDA”).

None

ITEM NO. 7 on the agenda was **ADJOURN UNTIL SEPTEMBER 5, 2023.**

Chairman Lloyd adjourned the Bethany Public Works meeting at 7:32 P.M. until September 5, 2023.

CHAIRMAN

SECRETARY

BETHANY PUBLIC WORKS AUTHORITY

From: Michael Vaughn, Finance Director
Date: August 30, 2023
Subject: Claims List for the 09/05/2023 Bethany Public Works Authority Meeting

BETHANY PUBLIC WORKS AUTHORITY

FUND	AMOUNT
Bethany Public Works Authority	\$8,944.94
Bethany Public Works Authority	\$442,661.06
TOTAL	\$451,606.00

ENTERPRISE-WIDE SUMMARY OF ALL CLAIMS:

FUND	AMOUNT
General Operations Fund	\$276,218.95
Bethany Public Works Authority	\$451,606.00
Bethany Hospital Trust	\$0.00
Bethany Development Authority	\$0.00
TOTAL	\$727,824.95

RECOMMENDATION

1. Approve the claims as presented.



FUND: 056- BETHANY PUBLIC WORKS AUTH

SUMMARY REPORT

P.O.#	VENDOR #	NAME	SUMMARY DESCRIPTION	DATE	INVOICE	AMOUNT
DEPARTMENT: 12.2		UTILITY - SEWER				
23-45061	10-004952	EPUMP SOLUTIONS	50TH MCMILLIAN	6/2023	3020597	8,944.94
DEPARTMENT TOTAL:						8,944.94
FUND TOTAL:						8,944.94
GRAND TOTAL:						10,800.58

P.O.#	VENDOR #	NAME	SUMMARY DESCRIPTION	DATE	INVOICE	AMOUNT
DEPARTMENT: N/A		NON-DEPARTMENTAL				
24-48623	10-3788	OKLAHOMA WATER RESOURCES	BOLOAN REPAYMENT	8/2023	20230915	143,830.28
DEPARTMENT TOTAL:						143,830.28
DEPARTMENT: 02.0		FINANCE				
24-48116	10-005350	FORCE PERSONNEL	TEMP METER READER BUTLER	8/2023	75414	1,704.99
24-48470	10-005373	CARD SERVICES/P1	PHONE SCREEN METER READ	8/2023	00588657	15.65
24-48594	10-005373	CARD SERVICES/P1	CARD STOCK CUT OFF'S/PENS	8/2023	0474641	27.26
24-48310	10-005702	TPS TECHNICAL PROGRAMMING	UTILITY BILLING SVC	8/2023	115451	3,864.81
24-48625	10-1085	OKLAHOMA MUNICIPAL ASSURANCWC	INSURANCE	8/2023	20230829	171.09
24-48164	10-3196	IMAGENET CONSULTING, LLC	2 CUSTOMER SVS COMPUTERS	8/2023	INV648940	1,046.66
DEPARTMENT TOTAL:						6,830.46
DEPARTMENT: 08.1		PUBLIC WORKS - ADMIN				
24-48389	10-005373	CARD SERVICES/P1	MONITOR, LAUNDRY SOAP, ZEVO	8/2023	01111436	113.10
24-48580	10-005373	CARD SERVICES/P1	INK, NITRILE GLOVES, GATORAD	8/2023	4427421	40.99
24-48296	10-1068	ONG	MONTHLY SVC	8/2023	20230816	190.60
24-48625	10-1085	OKLAHOMA MUNICIPAL ASSURANCWC	INSURANCE	8/2023	20230829	85.55
24-48160	10-3042	ACCURATE ENVIRONMENTAL	VOC 7 & 10 & BAC - T	8/2023	FG27074	736.00
DEPARTMENT TOTAL:						1,166.24
DEPARTMENT: 08.3		PUBLIC WORKS - SANIT				
24-48122	10-005350	FORCE PERSONNEL	SANITATION TEMP HELP	8/2023	75333	4,377.25
24-48271	10-005373	CARD SERVICES/P1	STORGE CLIPBOARD, WHITEBOA	8/2023	2005005	23.29
24-48445	10-005373	CARD SERVICES/P1	SUPPLIES FOR DEPTMENTS	8/2023	5923432	49.95
24-48541	10-005373	CARD SERVICES/P1	GREEN TAGS FOR SANITATION	8/2023	108947	172.17
24-48580	10-005373	CARD SERVICES/P1	INK, NITRILE GLOVES, GATORAD	8/2023	4427421	195.76
24-48428	10-005992	AEG PETROLEUM	200 GAL DEF FLUID	8/2023	822823	446.72
24-48427	10-0225	GENUINE PARTS	FILTER & 3 GALS TRANS OIL	8/2023	-039917	185.35
24-48463	10-0572	REDDY ICE CORP	60 BAGS OF ICE	8/2023	3850645358	37.88
24-48590	10-0812	J & R EQUIPMENT LLC	REPAIR KICKBAR & WELDED HOLES	8/2023	01W4958	1,603.80
24-48625	10-1085	OKLAHOMA MUNICIPAL ASSURANCWC	INSURANCE	8/2023	20230829	10,950.11
24-48584	10-1261	RED ROCK PETRO	5200 UNLEAD & 2800 DIESEL	8/2023	1459625	5,299.12
24-48603	10-1622	WESTLAKE ACE HARDWARE	AIR FILTER, PRIMER PVC, SCRE	8/2023	3503679	1.40
24-48308	10-2305	HOIDALE CO INC	REPAIR SPILL & RISER	8/2023	114120	5,111.23
24-48365	10-3196	IMAGENET CONSULTING, LLC	FIRE WALL LICENSE	8/2023	INV650578	886.32
24-48234	10-4012	WASTE CONNECTIONS, INC	LANDFILL FEES	8/2023	30324	26,165.73
DEPARTMENT TOTAL:						55,506.08

FUND: 056- BETHANY PUBLIC WORKS AUTH

SUMMARY REPORT

P.O.#	VENDOR #	NAME	SUMMARY DESCRIPTION	DATE	INVOICE	AMOUNT
DEPARTMENT: 08.4 PUBLIC WORKS - MAINT						
24-48625	10-1085	OKLAHOMA MUNICIPAL ASSURANCWC INSURANCE		8/2023	20230829	171.10
24-48584	10-1261	RED ROCK PETRO	5200 UNLEAD&2800 DIESEL	8/2023	1459625	528.27
24-48563	10-2305	HOIDALE CO INC	SERVICE CALL TEST ERROR	8/2023	1142690	157.25
24-48564	10-3488	CLIFFORD POWER SYSTEMS, INC	INCDX GENERATOR ISSUES	8/2023	SVC-0151949	169.46
DEPARTMENT TOTAL:						1,026.08
DEPARTMENT: 12.0 UTILITY - WATER PLANT						
24-48484	10-004725	RUCKER ELECTRIC INCORPORATED	ELECTRICAL ISSUE WELL7	8/2023	12778	188.75
24-48527	10-004725	RUCKER ELECTRIC INCORPORATED	WELL 27	8/2023	12829	155.00
24-48271	10-005373	CARD SERVICES/PI	STORGE CLIPBOARD,WHITEBOA	8/2023	3325803	115.00
24-48445	10-005373	CARD SERVICES/PI	SUPPLIES FOR DEPTMENTS	8/2023	5923432	197.59
24-48580	10-005373	CARD SERVICES/PI	INK,NITRILEGLOVES,GATORAD	8/2023	4427421	94.92
24-48428	10-005992	AEG PETROLEUM	200 GAL DEF FLUID	8/2023	822823	13.96
24-48433	10-0091	BRENNTAG SOUTHWEST INC	4/55GALORTHOPOLYPHOSH	8/2023	BSW486908	1,990.29
24-48434	10-0091	BRENNTAG SOUTHWEST INC	2 TOTES OF ALUMINUM	8/2023	BSW485515	2,520.00
24-48436	10-0091	BRENNTAG SOUTHWEST INC	4000 GALLONS OF BLEACH	8/2023	BSW485516	7,877.53
24-48437	10-0091	BRENNTAG SOUTHWEST INC	2 TOTES OF AQUA AMMONIA	8/2023	BSW485514	1,811.00
24-48568	10-0091	BRENNTAG SOUTHWEST INC	2 TOTES OF ALUM SULF	8/2023	BSW488977	2,697.50
24-48570	10-0091	BRENNTAG SOUTHWEST INC	4200 GALS BLEACH	8/2023	BSW488980	8,260.15
24-48571	10-0091	BRENNTAG SOUTHWEST INC	2 TOTES OF AQUA AMMONIA	8/2023	BSW488979	1,633.50
24-48446	10-0225	GENUINE PARTS	BATTERY,S,FUEL FILTER CAP	8/2023	7092-040018	295.33
24-48463	10-0572	REDDY ICE CORP	60 BAGS OF ICE	8/2023	3850645358	37.87
24-48282	10-1063	OG&E	MNTHLY SVC	8/2023	20230807	6,350.69
24-48296	10-1068	ONG	MNTHLY SVC	8/2023	20230816	314.09
24-48625	10-1085	OKLAHOMA MUNICIPAL ASSURANCWC INSURANCE		8/2023	20230829	3,507.46
24-48143	10-1128	OK CITY WATER UTILITIES	TRCROSSTIES	8/2023	BASE	60,499.59
24-48584	10-1261	RED ROCK PETRO	5200 UNLEAD&2800 DIESEL	8/2023	1459625	458.03
24-48464	10-1622	WESTLAKE ACE HARDWARE	LATCH,BOLTS,&SCREWS	8/2023	3503654	16.99
24-48531	10-1622	WESTLAKE ACE HARDWARE	PVC,CEMENT,WEEDEATERLINE	8/2023	3503661	71.85
24-48308	10-2305	HOIDALE CO INC	REPAIR SPILL & RISER	8/2023	114120	159.73
24-48440	10-2660	ODEQ WATER QUALITY DIV	WATER&WASTEWATERLICENSE	8/2023	23060163864	184.00
24-48610	10-2660	ODEQ WATER QUALITY DIV	VALESIA LABELLE	8/2023	23060167265	110.00
24-48160	10-3042	ACCURATE ENVIRONMENTAL	VOC 7 & 10 & BAC - T	8/2023	FG27079	600.00
24-48418	10-3042	ACCURATE ENVIRONMENTAL	VOC 7 & 10 /BACT	8/2023	FH09112	310.00
24-48364	10-3196	IMAGENET CONSULTING, LLC	WATER DEPT COMPUTER	8/2023	INV660791	1,336.16
24-48365	10-3196	IMAGENET CONSULTING, LLC	FIRE WALL LICENSE	8/2023	INV650578	1,495.68
24-48431	10-3487	AIRGAS USA, LLC	20 TONS OF CO2	8/2023	9141265928	4,898.56
24-48435	10-3919	MISSISSIPPI LIME	25 TONS OF LIME	8/2023	1686330	8,771.06
24-48565	10-3919	MISSISSIPPI LIME	25 TONS OF LIME	8/2023	1687577	8,516.47
DEPARTMENT TOTAL:						125,488.75

P.O.#	VENDOR #	NAME	SUMMARY DESCRIPTION	DATE	INVOICE	AMOUNT
DEPARTMENT: 12.1		UTILITY - WATER LINE				
24-48271	10-005373	CARD SERVICES/PI	STORGE CLIPBOARD,WHITEBOA	8/2023	2005005	236.88
24-48445	10-005373	CARD SERVICES/PI	SUPPLIES FOR DEPTMENTS	8/2023	5923432	80.70
24-48580	10-005373	CARD SERVICES/PI	INK,NITRILEGLOVES,GATORAD	8/2023	4427421	98.19
24-48547	10-005451	MATTHEWS TRENCHING CO.,	INCLABOR & EQUIPMENT	8/2023	7711 NW 20th	7,500.00
24-48428	10-005992	AEG PETROLEUM	200 GAL DEF FLUID	8/2023	822823	13.96
24-48556	10-0609	BOBCAT OF OKLAHOMA CITY	REPAIR MINI #49B	8/2023	W33615	3,226.72
24-48451	10-1066	OKLAHOMA CONTRACTOR'S SUPPL	CLAMPS FOR STOCK	8/2023	0376017-IN	550.00
24-48536	10-1066	OKLAHOMA CONTRACTOR'S SUPPL	HIGH MAX CLAMPS	8/2023	0376016	310.00
24-48625	10-1085	OKLAHOMA MUNICIPAL ASSURANC	WC INSURANCE	8/2023	20230829	2,908.62
24-48584	10-1261	RED ROCK PETRO	5200 UNLEAD&2800 DIESEL	8/2023	1459625	608.97
24-48422	10-1288	ROSE STATE COLLEGE	LANDON WENGER	8/2023	1002250	243.00
24-48538	10-1509	TOM'S SPEEDY LOCK & KEY SERA	AFTER HOURS KEY FOR LOCKS	8/2023	69556	5.50
24-48603	10-1622	WESTLAKE ACE HARDWARE	AIR FILTER,PRIMERPVC,SCRE	8/2023	3503680	19.98
24-48639	10-1622	WESTLAKE ACE HARDWARE	4 LED LIGHT BULBS	8/2023	3503696	6.99
24-48510	10-1841	CAVENDER FORD OF OKC	IGNITION LOCK CYLINDER#30	8/2023	535811	65.46
24-48308	10-2305	HOIDALE CO INC	REPAIR SPILL & RISER	8/2023	114120	159.72
24-48212	10-2557	CORE & MAIN LP	FORD BRASS FITTING	8/2023	T417063	1,510.16
24-48213	10-2557	CORE & MAIN LP	10 NEPTUNE MACH 10 METERS	8/2023	T417098	3,750.00
24-48334	10-2557	CORE & MAIN LP	TWO 2 INCH CLAPS	8/2023	T309581	231.06
24-48336	10-2557	CORE & MAIN LP	2 COMPRESSION FITTINGS	8/2023	T311918	120.00
24-48340	10-2557	CORE & MAIN LP	20FOOT 2IN PVC PIPE	8/2023	T314955	39.00
24-48379	10-2557	CORE & MAIN LP	18 X 18 METER CANS	8/2023	T345790	1,826.70
24-48471	10-2557	CORE & MAIN LP	TOOLS	8/2023	2275,2245	899.14
24-48504	10-2660	ODEQ WATER QUALITY DIV	LANDON ODEQ TEST	8/2023	OE4547946	62.00
24-48627	10-2895	CHAPPELL SUPPLY	3 INCH TRASH PUMP	8/2023	0349258-IN	577.28
DEPARTMENT TOTAL:						25,050.03
DEPARTMENT: 12.2		UTILITY - SEWER				
24-48442	10-004725	RUCKER ELECTRIC INCORPORATE	INSTALL NEW PUMP	8/2023	12777	222.50
24-48499	10-004725	RUCKER ELECTRIC INCORPORATE	50TH MCMILLAIN	8/2023	12772	699.68
24-48582	10-004952	EPUMP SOLUTIONS	REPAIRS FOR 10HP PUMP	8/2023	3020629	3,858.00
24-48341	10-005005	BRONCO EQUIPMENT RENTAL & S	RENTAL OF MINI	8/2023	862287-0001	320.51
24-48389	10-005373	CARD SERVICES/PI	MONITOR,LAUNDRYSOAP,ZEVO	8/2023	01111436	27.96
24-48580	10-005373	CARD SERVICES/PI	INK,NITRILEGLOVES,GATORAD	8/2023	4427421	98.19
24-48477	10-0091	BRENNTAG SOUTHWEST INC	CLEANUP FOR OVERSPILLS	8/2023	BSW487230, 488978	675.00
24-48132	10-0812	J & R EQUIPMENT LLC	DX SEWER JETTER	8/2023	01W4943	963.09
24-48480	10-0883	LOCKE SUPPLY CO.	FERNCO'S&6X6COUPLING	8/2023	50303863	109.34
24-48282	10-1063	OG&E	MNTHLY SVC	8/2023	20230807	1,429.17
24-48625	10-1085	OKLAHOMA MUNICIPAL ASSURANC	WC INSURANCE	8/2023	20230829	1,197.67
24-48584	10-1261	RED ROCK PETRO	5200 UNLEAD&2800 DIESEL	8/2023	1459625	150.94
24-48422	10-1288	ROSE STATE COLLEGE	LANDON WENGER	8/2023	1002250	243.00
24-48441	10-2123	HOME DEPOT CREDIT SVCS	ROPE,PLIERS,ALUM.STOPSET	8/2023	011029/9522192	112.72
24-48471	10-2557	CORE & MAIN LP	TOOLS	8/2023	2275,2245	490.05
24-48504	10-2660	ODEQ WATER QUALITY DIV	LANDON ODEQ TEST	8/2023	OE4547946	62.00
24-48392	10-2828	UNITED RENTALS (NORTH AMERIB	YPASS PUMP	8/2023	223125928-001	3,206.17
24-48455	10-3245	KRAPFF REYNOLDS CONST CO	EMERGENCY REPAIR	8/2023	23139	33,300.00
24-48396	10-3434	W & W ELECTRIC MOTOR SVC	REPAIR75HPSUBMERIBLEPUMP	8/2023	2049	12,750.00

P.O.#	VENDOR #	NAME	SUMMARY DESCRIPTION	DATE	INVOICE	AMOUNT
DEPARTMENT: 12.2 UTILITY - SEWER						
24-48579	10-4010	HARD HAT SAFETY & GLOVE	PPE SUPPLIES	8/2023	IN-0064647	152.00
DEPARTMENT TOTAL:						60,067.99
DEPARTMENT: 97.0 DEBT SERVICE						
24-48623	10-3788	OKLAHOMA WATER RESOURCES	BOLOAN REPAYMENT	8/2023	20230915	23,695.15
DEPARTMENT TOTAL:						23,695.15
FUND TOTAL:						442,661.06
GRAND TOTAL:						717,024.37

NOTICE: On Monday, August 14, 2023, at or before 4:59 p.m., agenda was posted at the front doors of City Hall, on the bulletin board in the lobby of City Hall, and on the City of Bethany website: cityofbethany.org. The City of Bethany encourages participation from all its citizens. If participation at any public meeting is not possible due to a disability, notification to the City Clerk at least 48 hours prior to the scheduled meeting is encouraged to make the necessary accommodations. The City may waive the 48-hour rule if signing is not the necessary accommodation.

BETHANY HOSPITAL TRUST MEETING

BETHANY CITY HALL

TUESDAY, AUGUST 15, 2023

6:30 P.M.

MEMBERS PRESENT:	Nikki Lloyd	Chairman
	Jeff Knapp	Vice-Chairman
	Chris Powell	Trustee
	Kathy Larsen	Trustee
	Brian Magirowsky	Trustee
	Ken Smart	Trustee
	Peter Plank	Trustee
	Steve Palmer	Trustee
MEMBERS ABSENT:	Marilyn McPhail	Trustee
OTHERS PRESENT:	Elizabeth Gray	City Manager
	Ray Jones	City Attorney
	Michael Vaughn	City Clerk/Treasurer
	Lesa LaMar	Deputy City Clerk
	Troy Rhodes	Architect
	(See Roster)	

Chairman Lloyd called the Bethany Hospital Trust meeting to order at 7:32 P.M.

ITEM NO. 1 on the agenda was **CONSENT DOCKET:**

- A. APPROVAL OF MINUTES FROM AUGUST 1, 2023, REGULAR MEETING.**
- B. APPROVAL OF CLAIMS: THESE CLAIMS HAVE BEEN FOUND TO BE IN ORDER BY STAFF AND PROPER AS TO FORM AND PROCEDURE AND ARE RECOMMENDED FOR PAYMENT. A COPY OF THE CLAIMS.**

Motion was made by Trustee Magirowsky, seconded by Trustee Larsen to approve the Consent Docket. Yes Votes: Larsen, Magirowsky, Powell, Smart, Plank, Lloyd, Palmer, Knapp. No Votes: None. Motion passed.

ITEM NO. 2 on the agenda was **NEW BUSINESS (AS DEFINED BY THE OKLAHOMA OPEN MEETING ACT § 311 (A) (9) AS “MATTERS NOT KNOWN ABOUT OR WHICH COULD NOT HAVE REASONABLY BEEN FORESEEN PRIOR TO THE TIME OF POSTING THE AGENDA”)**.

None

ITEM NO. 3 on the agenda was **ADJOURN UNTIL SEPTEMBER 5, 2023.**

Chairman Lloyd adjourned the Bethany Hospital Trust meeting at 7:33 P.M. until September 5, 2023.

CHAIRMAN

SECRETARY

BETHANY HOSPITAL TRUST

From: Michael Vaughn, Finance Director
Date: August 30, 2023
Subject: Claims List for the 09/05/2023 Bethany Hospital Trust Meeting

BETHANY HOSPITAL TRUST

FUND	AMOUNT
Bethany Hospital Trust	\$0.00
TOTAL	\$0.00

ENTERPRISE-WIDE SUMMARY OF ALL CLAIMS:

FUND	AMOUNT
General Operations Fund	\$276,218.95
Bethany Public Works Authority	\$451,606.00
Bethany Hospital Trust	\$0.00
Bethany Development Authority	\$0.00
TOTAL	\$727,824.95

RECOMMENDATION

1. Approve the claims as presented.



NOTICE: On Monday August 1, 2023, at or before 4:59 p.m., agenda was posted at the front doors of City Hall, on the bulletin board in the lobby of City Hall, and on the City of Bethany website: cityofbethany.org. The City of Bethany encourages participation from all its citizens. If participation at any public meeting is not possible due to a disability, notification to the City Clerk at least 48 hours prior to the scheduled meeting is encouraged to make the necessary accommodations. The City may waive the 48-hour rule if signing is not the necessary accommodation.

BETHANY DEVELOPMENT AUTHORITY

BETHANY CITY HALL

TUESDAY, AUGUST 15, 2023

7:30 P.M.

MEMBERS PRESENT:	Nikki Lloyd	Chairman
	Jeff Knapp	Vice-Chairman
	Chris Powell	Trustee
	Steve Palmer	Trustee
	Kathy Larsen	Trustee
	Brian Magirowsky	Trustee
	Ken Smart	Trustee
	Peter Plank	Trustee
MEMBERS ABSENT:	Marilyn McPhail	Trustee
OTHERS PRESENT:	Elizabeth Gray	City Manager
	Ray Jones	City Attorney
	Michael Vaughn	City Clerk/Treasurer
	Lesa LaMar	Deputy City Clerk
	Troy Rhodes	Architect
	(See Roster)	

Chairman Lloyd called the Bethany Development Authority meeting to order at 7:33 P.M.

ITEM NO. 1 on the agenda was **CONSENT DOCKET:**

- A. APPROVAL OF MINUTES FROM AUGUST 1, 2023, REGULAR MEETING.**
- B. APPROVAL OF CLAIMS: THESE CLAIMS HAVE BEEN FOUND TO BE IN ORDER BY STAFF AND PROPER AS TO FORM AND PROCEDURE AND ARE RECOMMENDED FOR PAYMENT. A COPY OF THE CLAIMS.**

Motion was made by Trustee Magirowsky, seconded by Trustee Larsen to approve the Consent Docket. Yes votes: Larsen, Lloyd, Plank, Smart, Palmer, Powell, Magirowsky, Knapp. No votes: None. Motion passed.

ITEM NO. 2 on the agenda was **NEW BUSINESS (AS DEFINED BY THE OKLAHOMA OPEN MEETING ACT § 311 (A) (9) AS “MATTERS NOT KNOWN ABOUT OR WHICH COULD NOT HAVE REASONABLY BEEN FORESEEN PRIOR TO THE TIME OF POSTING THE AGENDA”)**.

None

ITEM NO. 3 on the agenda was **ADJOURN UNTIL SEPTEMBER 5, 2023.**

Chairman Lloyd adjourned the Bethany Development Authority meeting at 7:33 P.M. until September 5, 2023.

CHAIRMAN

SECRETARY

BETHANY DEVELOPMENT AUTHORITY

From: Michael Vaughn, Finance Director
Date: August 30, 2023
Subject: Claims List for the 09/05/2023 Bethany Development Authority Meeting

BETHANY DEVELOPMENT AUTHORITY

FUND	AMOUNT
Bethany Development Authority	\$0.00
TOTAL	\$0.00

ENTERPRISE-WIDE SUMMARY OF ALL CLAIMS:

FUND	AMOUNT
General Operations Fund	\$276,218.95
Bethany Public Works Authority	\$451,606.00
Bethany Hospital Trust	\$0.00
Bethany Development Authority	\$0.00
TOTAL	\$727,824.95

RECOMMENDATION

1. Approve the claims as presented.

